



CITY OF ROOSEVELT PARK CITY COUNCIL MEETING

AGENDA
May 20, 2024
6:15 p.m.

1. Council Work Session
2. Call to Order and Roll Call
3. Pledge of Allegiance
4. Invocation by Councilmember Crossno
5. Public Comment on Agenda Items

6. Approval of Consent Agenda
 - a. Regular Agenda
 - b. Minutes of the May 13, 2024- Regular City Council Meeting
 - c. List of Bills

7. Unfinished Business

8. New Business
 - a. 2024 Category B Grant Program Bids-Eastland/Royal Oak Project
 - b. 2024 Roosevelt Park Day Committee-Set June Meeting Time and Date

9. Public Comment

Please state your name and home address
Please limit comments to 3 minutes per individual presentation
(City Council Rules of Procedure: 10/7/2011)

10. Comments from the Mayor and City Council
11. Reports from City Manager, City Attorney & Department Heads
12. Adjournment

American Disability Act Compliance: For access to open meetings of the City Council and any of its committees or subcommittees, the City of Roosevelt Park will provide necessary reasonable auxiliary aids and services, to individuals with disabilities who want to attend the meeting, upon twenty-four-hour notice to the City of Roosevelt Park. Individuals with disabilities requiring auxiliary aids or services should contact the City of Roosevelt Park, City Clerk by writing or calling, 231-755-3721 or call the following: TDD: Dial 7-1-1 and request a representative to dial 231-755-3721.



City of Roosevelt Park

A Proud Community

To: Honorable Mayor and City Council
From: Jared Olson, City Manager
Date: May 16, 2024
Subject: **Monday, May 20, 2024**– CITY COUNCIL MEETING

The following is information pertaining to items on the agenda for your meeting:
COUNCIL WORK SESSION:

1. Active Agenda Items

COUNCIL MEETING:

- a. **2024 Category B Grant Program Bids-Eastland/Royal Oak Project-** The City of Roosevelt Park was awarded \$232,000 from the Michigan Department of Transportation Economic Development Fund Category B (MDOT TEDF Cat. B) program to help reconstruct Eastland from Glenside to Royal Oak along with nearly four hundred feet of Royal Oak. As such, Moore and Bruggink were approved to be engineers of record for the project and after designing the project and issuing a public request for proposals, multiple contractors submitted bids for the project. Ryan Arends from Moore and Bruggink will be in attendance to review the project and the bids.
- b. **2024 Roosevelt Park Day Committee-Set June Meeting Time and Date-** The next meeting time and date is needed for the planning of the 2024 Roosevelt Park Day event. Staff is recommending looking at the week of June 3rd.

If you have questions, please contact me.



**CITY OF ROOSEVELT PARK
CITY COUNCIL
MEETING MINUTES
May 13, 2024**

This meeting was called to order by Mayor Aaron Langlois at 6:15 p.m.

PRESENT: Council Members: Mayor Aaron Langlois, Mayor Pro-Tem Michael Sutton, Stacey Burmeister, Diane Goodman, Noah Crossno, Matt Johnson

STAFF: City Manager Jared Olson, City Clerk Ann Wisniewski, City Attorney John Schrier, Police Officer Ray Ryder

ABSENT: Fawn Cruz

WORK SESSION

Council discussed Agenda Items:

- Downtown Development Authority Board Resignation
- Downtown Development Authority Board Application
- 2024 National Police Week Resolution – Council Approval
- 2024 Public Works Week Resolution – Council Approval
- 2024 Parks Capital Update Recommendation – Council Approval
- 2026 EGLE Drinking Water Loan – Service Line Project – Intent to Apply
- List of Bills

Special Guests:

- None

Mayor Langlois called the Council meeting to order at 6:50 p.m.

2024-81

ROLL CALL

City Clerk Ann Wisniewski called roll call.

2024-82

INVOCATION

Council Member Goodman provided the Invocation.

2024-83

PUBLIC COMMENT ON AGENDA ITEMS

Michael Ciulis - 1543 Cornell Rd. shared comments

2024-84

CONSENT AGENDA

A motion was made by Council Member Crossno to approve the consent agenda as written. This motion was supported by Council Member Burmeister.

Roll Call: 6 Ayes, 0 Nays, 1 absent (Cruz) - Motion Passes

2024-85 **UNFINISHED BUSINESS**

None

2024-86 **NEW BUSINESS**

8A. Downtown Development Authority Board Resignation – Council Acceptance

Council Member Goodman moved to accept the resignation of Pam Hanophy from the City of Roosevelt Park Downtown Development Authority Board. This motion was supported by Mayor Problem Sutton.

Roll Call: 6 Ayes, 0 Nays, 1 Absent (Cruz) – Motion Passes

8B. Downtown Development Authority Board Application – Council Appointment

Council Member Burmeister moved to appoint Kim Bourdo from Service 1 Credit Union to the DDA Board of Directors for the vacant four-year-term expiring December 2024. This motion was supported by Council Member Crossno.

Roll Call: 6 Ayes, 0 Nays, 1 Absent (Cruz) – Motion Passes

8C. 2024 National Police Week Resolution – Council Approval

Council Member Goodman moved to adopt the resolution with appreciation and acknowledge the dedication and support of law enforcement along with the observation of National Police Week 2024. This motion was supported by Council Member Burmeister.

Roll Call: 6 Ayes, 0 Nays, 1 Absent (Cruz) – Motion Passes

8D. 2024 Public Works Week Resolution – Council Approval

Council Member Johnson moved to adopt the resolution with appreciation and acknowledge the dedication and support of the entire Department of Public Works in observation of National Public Works Week 2024.

Roll Call: 6 Ayes, 0 Nays, 1 Absent (Cruz) – Motion Passes

8E. 2024 Parks Capital Update Recommendation – Council Approval

Council Member Burmeister moved to approve the modified design from Park Vision as Presented and authorize the City Manager and City Clerk to finalize all needed purchase and order documents.

Roll Call: 5 Ayes, 0 Nays, 1 Abstain (Crossno), 1 Absent (Cruz) – Motion Passes

8F. 2026 EGLE Drinking Water Loan – Service Line Project – Intent to Apply

Council Member Crossno moved to authorize staff to complete the FY2026 Drinking Water Revolving Fund (DWRF) Intent to Apply for funds to assist in funding of the State Mandated water service line replacement. This motion was supported by Council Member Burmeister.

Roll Call: 6 Ayes, 0 Nays, 1 Absent (Cruz) – Motion Passes

2024-87 **COUNCIL COMMENTS**

Council members shared comments.

2024-88 **DEPARTMENT HEAD REPORTS**
Department Heads shared comments.

2024-89 **PUBLIC COMMENTS**
None

2024-90 **ADJOURNMENT**
Mayor Langlois moved to adjourn the meeting at 7:30 p.m. This motion was supported by Mayor Pro-Tem Sutton and carried unanimously.

Ann Wisniewski, City Clerk



CITY OF ROOSEVELT PARK

A Proud Community
900 OAK RIDGE ROAD
ROOSEVELT PARK, MI 49441
(231) 755-3721

COUNCIL LIST

CHECK NUMBER	VENDOR NAME	DESCRIPTION	Invoice #	INVOICE AMT
4606 (E)	ACCIDENT FUND	WORKERS COMP INSURANCE - JUNE	1001088948	1,308.30
			Check Total	1,308.30
4607 (E)	BANK OF AMERICA BUSINESS CARD	MICROSOFT OFFICE	E0400RXRYQ	52.47
		MMTA CONFERENCE - BAY CITY	673887A	427.77
		CONFERENCE REFUND	REFUND2024	(200.00)
			Check Total	280.24
4608 (E)	BANK OF AMERICA BUSINESS CARD	BALLFIELD - SCOREBOARD	6811	250.00
			Check Total	250.00
4609 (E)	BANK OF AMERICA BUSINESS CARD	MME SUMMER WORKSHOP	2024WORKSHOP	350.00
			Check Total	350.00
4610 (E)	BANK OF AMERICA BUSINESS CARD	ONLINE CODE HOSTING - CODE OF ORDINANCE	303929	480.00
		CONFERENCE REFUND	REFUND2024	(475.00)
			Check Total	5.00
4611 (E)	BLUE CARE NETWORK OF MI	RETIREE HEALTH CARE	241280002752	1,641.36
			Check Total	1,641.36
4612 (E)	BLUE CROSS BLUE SHIELD OF MICH	RETIREE HEALTH CARE	183521975	2,171.43
			Check Total	2,171.43
4613 (E)	CONSUMERS ENERGY	2802 GLENSIDE BLVD	203500235242	44.95
		2686 GLENSIDE BLVD	203500235241	78.53
			Check Total	123.48
4614 (E)	CONSUMERS ENERGY	1000 0015 1900 2848 ASHLAND	207147548580	53.72
			Check Total	53.72
4615 (E)	CONSUMERS ENERGY	1000 0015 2536 - 896 W BROADWAY	207147548594	53.23
			Check Total	53.23
4616 (E)	CONSUMERS ENERGY	1000 0460 5042 3105 ROOSEVELT	206258753677	62.20
			Check Total	62.20
4617 (E)	CONSUMERS ENERGY	1000 0460 5166 3106 ROOSEVELT	206258753678	66.06
			Check Total	66.06
4618 (E)	CONSUMERS ENERGY	1000 0597 2995 1168 CORNELL	204390139174	31.38
			Check Total	31.38
4619 (E)	CONSUMERS ENERGY	1000 0616 4881 1580 GARRISON	204479100496	293.90
			Check Total	293.90
4620 (E)	CONSUMERS ENERGY	1000 0616 6274 3064 GLENSIDE	204479100497	29.38
			Check Total	29.38
4621 (E)	CONSUMERS ENERGY	1000 0622 0758 1344 GREENWICH RD	204479100498	29.08
			Check Total	29.08
4622 (E)	CONSUMERS ENERGY			

**CITY OF ROOSEVELT PARK**

A Proud Community
 900 OAK RIDGE ROAD
 ROOSEVELT PARK, MI 49441
 (231) 755-3721

COUNCIL LIST

Wednesday, May 15, 2024

CHECK NUMBER	VENDOR NAME	DESCRIPTION	Invoice #	INVOICE AMT
	1000 0628 6080 1502 HAVERHILL		203500227823	31.84
			Check Total	31.84
4623 (E)	CONSUMERS ENERGY			
	1000 0678 0280 898 W BROADWAY		204835064467	90.09
			Check Total	90.09
4624 (E)	CONSUMERS ENERGY			
	1000 0777 1684 880 OAKRIDGE		202254364744	441.51
			Check Total	441.51
4625 (E)	CONSUMERS ENERGY			
	1000 0783 4730 901 POST RD		201275497286	29.22
			Check Total	29.22
4626 (E)	CONSUMERS ENERGY			
	1000 0832 5373 3278 GERMAINE		201364469007	34.46
			Check Total	34.46
4627 (E)	CONSUMERS ENERGY			
	1000 0864 3968 1267 LAMBERT		201898379492	36.48
			Check Total	36.48
4628 (E)	CONSUMERS ENERGY			
	1000 0849 1167 3163 MAPLE GROVE		201898379493	28.77
			Check Total	28.77
4629 (E)	CONSUMERS ENERGY			
	1000 0864 2272 1140 SHERWOOD		201898379494	29.22
			Check Total	29.22
4630 (E)	ETNA SUPPLY COMPANY			
	DDA SPRINKLING SUPPLIES		S105660712.0	577.97
			Check Total	577.97
4631 (E)	HOME DEPOT CREDIT SERVICES			
	STREET SUPPLIES/GLENSIDE SPRINKING/PARKS		051324	554.82
			Check Total	554.82
4632 (E)	MICHIGAN STATE POLICE			
	SOR 4-30-24		551-636638	150.00
			Check Total	150.00
4633 (A)	ASPHALT PAVING, INC.			
	PATCH		API-0003270	44.80
			Check Total	44.80
4634 (A)	BOSSE HOME SERVICES, LLC			
	CODE ENFORCEMENT MOWING - 1344 PRINCETON		032419	75.00
			Check Total	75.00
4635 (A)	CITY OF NORTON SHORES			
	LOCKBOX LID - 3275 HENRY		24-0003465	188.00
	HENRY ST TRAFFIC SIGNALS		24-0003721	743.42
			Check Total	931.42
4636 (A)	CORE & MAIN			
	5/8 X 3/4 ADAPTER		U762274	486.90
			Check Total	486.90
4637 (A)	EMERGENCY SERVICES LLC			
	UNIT 3 - TIRE REPAIR		21229	29.70
			Check Total	29.70
4638 (A)	KENT COMMUNICATIONS INC			
	SUMMER TAX BILL POSTAGE		233900	730.58
			Check Total	730.58
4639 (A)	MCU CONSTRUCTION			
	SIDEWALK REPLACEMENT		579985	4,200.00

**CITY OF ROOSEVELT PARK**

A Proud Community
 900 OAK RIDGE ROAD
 ROOSEVELT PARK, MI 49441
 (231) 755-3721

COUNCIL LIST

Wednesday, May 15, 2024

CHECK NUMBER	VENDOR NAME	DESCRIPTION	Invoice #	INVOICE AMT
			Check Total	4,200.00
4640 (A)	MOORE & BRUGGINK, INC.	ROYAL OAK/EASTLAND	240129.1-4	1,118.53
			Check Total	1,118.53
4641 (A)	PREIN & NEWHOF, P.C	GLENSIDE BLVD - MDOT PAPERWORK	81616	706.75
		BROADWAY RESURFACING	81621	2,000.00
			Check Total	2,706.75
4642 (A)	PRO CLEAN SOLUTIONS	BUILDING CLEANING - APRIL	ROO050124	375.00
			Check Total	375.00
4643 (A)	STEVE DEMETRIOUS	RP DAY DEPOSIT	2024RPDAY	500.00
			Check Total	500.00
4644 (A)	WEST MICHIGAN UNIFORM	DPW UNIFORM CLEANING	5822307	50.00
		DPW UNIFORM CLEANING	5824136	50.00
			Check Total	100.00
38326	CJ MASONRY, LLC	BROADWAY BRICK COLUMN REPAIR	11267	2,990.00
			Check Total	2,990.00
38327	FIELDS OUTDOOR ADVENTURES	AMMO - 9MM, 1000 ROUNDS	1454	317.55
			Check Total	317.55
38328	KATHYS ALTERATIONS & REPAIRS	PD UNIFORMS	201114	13.00
			Check Total	13.00
38329	MELLEMA NURSERY	TREES - DTE GRANT	1581	2,170.00
			Check Total	2,170.00
38330	MI PAVEMENT MARKINGS LLC	ROAD STRIPING	PARK-2401	2,642.86
			Check Total	2,642.86
38331	MLIVE MEDIA GROUP	ROYAL OAK/EASTLAND RFP	1601011	430.00
			Check Total	430.00
38332	SHERWIN WILLIAMS	STRIPING PAINT	4375-0	73.54
			Check Total	73.54
			Report Total	28,688.77



CITY OF ROOSEVELT PARK CITY COUNCIL MEETING May 20, 2024

2024 Category B Grant Program Bids-Eastland/Royal Oak Project	Date: May 20, 2024
<p>Summary: In November 2023, the City of Roosevelt Park was awarded \$232,050 in Michigan Department of Transportation (MDOT) funds through the Transportation and Economic Development Fund Category B grant program to reconstruct Eastland from Glenside to Royal Oak and portion of Royal Oak. This project includes the reconstruction of both streets, along with the addition of a brand-new storm drain system that will eventually connect to the feeder streets to the south.</p> <p>The City has a project match requirement of \$232,050 along with any costs not included under the grant contract limits. Moore and Bruggink who are our project engineers have finalized the plans and issued a request for proposals for the project. Those sealed bids were submitted, and the bid opening occurred on May 15th. Attached to this is a project overview and the bids as submitted by qualified contractors for the project.</p> <p>Mr. Ryan Arends from Moore and Bruggink will be in attendance to review the project and present the bids.</p>	
<p>Financial Impact: This is a budgeted 2024 project and the low bid was \$169,000 under original estimates at \$498,138.65 by Jackson-Merkey Contractors.</p>	
<p>Recommendation: Staff and Engineers recommendation is to accept the low bid as submitted by Jackson-Merkey at the proposed cost of \$498,138.65</p>	
<p>Signature:</p>	<p>Title: City Manager</p>



Moore+Bruggink
Consulting Engineers

May 15, 2024

Re: Royal Oak and Eastland Road
Improvements
Project No. 240129.01

Mr. Jared Olson, City Manager
City of Roosevelt Park
900 Oak Ridge Road
Muskegon, Michigan 49441

Dear Mr. Olson:

Five bids were received at 11 a.m., on Wednesday, May 15, 2024, for the **Royal Oak and Eastland Improvements** project. All bids were reviewed and checked for accuracy. A copy of the tabulation of bids is attached.

Jackson-Merkey Contractors submitted the low bid for the project in the amount of \$498,138.65. The engineer's estimate was \$668,000.00.

The low bidder has a satisfactory performance record on previous projects, and we recommend that a contract be awarded to Jackson-Merkey Contractors in the amount of \$498,138.65.

Sincerely,

Ryan M. Arends, P.E.
Project Engineer

RMA/pim
Attachment

cc: Ben VanHoeven, DPW Superintendent
Jackson-Merkey Contractors

MOORE & BRUGGINK, INC.
TABULATION OF BIDS

PROJECT: Royal Oak & Eastland Improvements – Project No. 240129.01

OWNER: City of Roosevelt Park, 900 Oak Ridge Road, Muskegon, Michigan 49441

BIDS RECEIVED: 11 a.m., Wednesday, May 15, 2024

ITEM NO.	PROPOSAL ITEM	UNIT	ESTIMATED QUANTITY	ENGINEER'S ESTIMATE		JACKSON-MERKEY CONTRACTORS		TERRA CONTRACTORS		McCORMICK SAND		TILES EXCAVATING		WEICK BROTHERS EXCAVATING	
				PRICE	AMOUNT	PRICE	AMOUNT	PRICE	AMOUNT	PRICE	AMOUNT	PRICE	AMOUNT	PRICE	AMOUNT
1	Mobilization, Max 10%	Lsum	1	\$60,190.00	\$60,190.00	\$49,000.01	\$49,000.01	\$48,000.00	\$48,000.00	\$55,000.00	\$55,000.00	\$50,000.00	\$50,000.00	\$40,000.00	\$40,000.00
2	Dr Structure, Rem	Ea	1	\$450.00	\$450.00	\$350.40	\$350.40	\$850.00	\$850.00	\$500.00	\$500.00	\$5,000.00	\$5,000.00	\$400.00	\$400.00
3	Curb and Gutter, Rem	Ft	200	\$15.00	\$3,000.00	\$8.67	\$1,734.00	\$12.00	\$2,400.00	\$7.00	\$1,400.00	\$25.00	\$5,000.00	\$18.00	\$3,600.00
4	Pavt, Rem	Syd	600	\$20.00	\$12,000.00	\$10.45	\$6,270.00	\$11.00	\$6,600.00	\$11.00	\$6,600.00	\$15.00	\$9,000.00	\$14.00	\$8,400.00
5	Sidewalk, Rem	Syd	200	\$20.00	\$4,000.00	\$6.30	\$1,260.00	\$9.00	\$1,800.00	\$11.00	\$2,200.00	\$10.00	\$2,000.00	\$14.00	\$2,800.00
6	Subgrade Undercutting, Type II	Cyd	100	\$40.00	\$4,000.00	\$0.01	\$1.00	\$23.00	\$2,300.00	\$25.00	\$2,500.00	\$40.00	\$4,000.00	\$24.00	\$2,400.00
7	Roadway Grading	Sta	12	\$3,000.00	\$36,000.00	\$5,800.00	\$69,600.00	\$5,150.00	\$61,800.00	\$6,600.00	\$79,200.00	\$1,600.00	\$19,200.00	\$5,400.00	\$64,800.00
8	Erosion Control, Inlet Protection, Silt Bag	Ea	9	\$150.00	\$1,350.00	\$208.06	\$1,872.54	\$120.00	\$1,080.00	\$120.00	\$1,080.00	\$150.00	\$1,350.00	\$250.00	\$2,250.00
9	Subbase, CIP	Cyd	1,150	\$30.00	\$34,500.00	\$0.01	\$11.50	\$18.00	\$20,700.00	\$10.00	\$11,500.00	\$20.00	\$23,000.00	\$22.00	\$25,300.00
10	Aggregate Base, 8 inch, 21AA, Modified	Syd	3,300	\$25.00	\$82,500.00	\$14.90	\$49,170.00	\$16.00	\$52,800.00	\$20.00	\$66,000.00	\$18.00	\$59,400.00	\$13.50	\$44,550.00
11	Sewer, CI E, 12 inch, Tr Det B	Ft	184	\$75.00	\$13,800.00	\$46.60	\$8,574.40	\$42.50	\$7,820.00	\$48.00	\$8,832.00	\$46.00	\$8,464.00	\$123.00	\$22,632.00
12	Sewer, CI E, 15 inch, Tr Det B	Ft	120	\$90.00	\$10,800.00	\$48.35	\$5,802.00	\$47.00	\$5,640.00	\$54.00	\$6,480.00	\$62.00	\$7,440.00	\$127.00	\$15,240.00
13	Sewer, CI E, 18 inch, Tr Det B	Ft	288	\$100.00	\$28,800.00	\$50.35	\$14,500.80	\$56.40	\$16,243.20	\$60.00	\$17,280.00	\$75.00	\$21,600.00	\$133.00	\$38,304.00
14	Sewer, CI E, 24 inch, Tr Det B	Ft	584	\$140.00	\$81,760.00	\$65.00	\$37,960.00	\$75.00	\$43,800.00	\$65.00	\$37,960.00	\$110.00	\$64,240.00	\$148.00	\$86,432.00
15	Storm Sewer, 6 inch, PVC, SDR 35	Ft	28	\$75.00	\$2,100.00	\$12.10	\$338.80	\$20.00	\$560.00	\$36.00	\$1,008.00	\$100.00	\$2,800.00	\$114.00	\$3,192.00
16	Dr Structure Cover, Adj, Case 1	Ea	1	\$850.00	\$850.00	\$728.50	\$728.50	\$750.00	\$750.00	\$1,250.00	\$1,250.00	\$500.00	\$500.00	\$600.00	\$600.00
17	Dr Structure Cover, Type B	Ea	6	\$900.00	\$5,400.00	\$994.50	\$5,967.00	\$750.00	\$4,500.00	\$625.00	\$3,750.00	\$1,052.00	\$6,312.00	\$620.00	\$3,720.00
18	Dr Structure Cover, Type C	Ea	2	\$1,000.00	\$2,000.00	\$1,253.00	\$2,506.00	\$1,300.00	\$2,600.00	\$800.00	\$1,600.00	\$1,596.00	\$3,192.00	\$900.00	\$1,800.00
19	Dr Structure Cover, Type K	Ea	6	\$1,000.00	\$6,000.00	\$1,242.00	\$7,452.00	\$1,160.00	\$6,960.00	\$800.00	\$4,800.00	\$1,580.00	\$9,480.00	\$900.00	\$5,400.00
20	Dr Structure, 24 inch dia	Ea	8	\$2,500.00	\$20,000.00	\$2,269.00	\$18,152.00	\$2,000.00	\$16,000.00	\$3,200.00	\$25,600.00	\$1,904.00	\$15,232.00	\$1,675.00	\$13,400.00
21	Dr Structure, 48 inch dia	Ea	4	\$3,000.00	\$12,000.00	\$3,840.95	\$15,363.80	\$2,800.00	\$11,200.00	\$3,700.00	\$14,800.00	\$2,152.00	\$8,608.00	\$2,405.00	\$9,620.00
22	Dr Structure, 60 inch dia	Ea	2	\$5,500.00	\$11,000.00	\$5,485.00	\$10,970.00	\$3,500.00	\$7,000.00	\$5,600.00	\$11,200.00	\$3,770.00	\$7,540.00	\$3,625.00	\$7,250.00
23	Dr Structure, Tap, 24 inch	Ea	1	\$1,000.00	\$1,000.00	\$1,378.00	\$1,378.00	\$1,800.00	\$1,800.00	\$1,500.00	\$1,500.00	\$3,500.00	\$3,500.00	\$400.00	\$400.00
24	HMA Surface, Rem	Syd	3,000	\$5.00	\$15,000.00	\$1.95	\$5,850.00	\$3.00	\$9,000.00	\$4.00	\$12,000.00	\$9.00	\$27,000.00	\$3.50	\$10,500.00
25	HMA, 13A	Ton	500	\$120.00	\$60,000.00	\$97.20	\$48,600.00	\$105.00	\$52,500.00	\$97.20	\$48,600.00	\$117.00	\$58,500.00	\$97.20	\$48,600.00
26	HMA, 36A	Ton	300	\$125.00	\$37,500.00	\$122.15	\$36,645.00	\$130.00	\$39,000.00	\$122.15	\$36,645.00	\$147.00	\$44,100.00	\$122.15	\$36,645.00
27	HMA Approach	Ton	35	\$150.00	\$5,250.00	\$200.00	\$7,000.00	\$220.00	\$7,700.00	\$200.00	\$7,000.00	\$240.00	\$8,400.00	\$200.00	\$7,000.00
28	Driveway, Nonreinf Conc, 6 inch	Syd	550	\$65.00	\$35,750.00	\$57.40	\$31,570.00	\$71.00	\$39,050.00	\$52.50	\$28,875.00	\$72.00	\$39,600.00	\$62.50	\$34,375.00
29	Curb and Gutter, Conc, Det F4	Ft	350	\$25.00	\$8,750.00	\$31.35	\$10,972.50	\$30.00	\$10,500.00	\$25.00	\$8,750.00	\$45.00	\$15,750.00	\$29.95	\$10,482.50
30	Curb Ramp Opening, Conc	Ft	60	\$30.00	\$1,800.00	\$31.35	\$1,881.00	\$32.00	\$1,920.00	\$25.00	\$1,500.00	\$45.00	\$2,700.00	\$31.00	\$1,860.00
31	Sidewalk, Conc, 4 inch	Sft	900	\$10.00	\$9,000.00	\$6.35	\$5,715.00	\$5.50	\$4,950.00	\$5.00	\$4,500.00	\$8.00	\$7,200.00	\$6.30	\$5,670.00
32	Curb Ramp, Conc, 6 inch	Sft	500	\$8.00	\$4,000.00	\$10.85	\$5,425.00	\$12.00	\$6,000.00	\$7.50	\$3,750.00	\$10.00	\$5,000.00	\$13.00	\$6,500.00
33	Traffic Control, Max 2%	Lsum	1	\$12,500.00	\$12,500.00	\$9,800.00	\$9,800.00	\$11,550.00	\$11,550.00	\$11,000.00	\$11,000.00	\$9,500.00	\$9,500.00	\$9,000.00	\$9,000.00
34	Turf Establishment	Syd	2,200	\$9.00	\$19,800.00	\$6.41	\$14,102.00	\$9.00	\$19,800.00	\$6.00	\$13,200.00	\$6.00	\$13,200.00	\$12.00	\$26,400.00
35	Water Main w/poly, 6 inch, w/sand backfill	Ft	20	\$200.00	\$4,000.00	\$31.25	\$625.00	\$150.00	\$3,000.00	\$34.00	\$680.00	\$200.00	\$4,000.00	\$110.00	\$2,200.00
36	Water Main, Rem	Ft	10	\$150.00	\$1,500.00	\$0.01	\$0.10	\$50.00	\$500.00	\$40.00	\$400.00	\$100.00	\$1,000.00	\$75.00	\$750.00

ITEM NO.	PROPOSAL ITEM	UNIT	ESTIMATED QUANTITY	ENGINEER'S ESTIMATE		JACKSON-MERKEY CONTRACTORS		TERRA CONTRACTORS		McCORMICK SAND		TILES EXCAVATING		WEICK BROTHERS EXCAVATING	
				PRICE	AMOUNT	PRICE	AMOUNT	PRICE	AMOUNT	PRICE	AMOUNT	PRICE	AMOUNT	PRICE	AMOUNT
37	Bend, 45 Degree, 6 inch	Ea	4	\$700.00	\$2,800.00	\$275.60	\$1,102.40	\$550.00	\$2,200.00	\$400.00	\$1,600.00	\$600.00	\$2,400.00	\$300.00	\$1,200.00
38	Sleeve, 6 inch	Ea	1	\$1,600.00	\$1,600.00	\$280.90	\$280.90	\$850.00	\$850.00	\$1,500.00	\$1,500.00	\$750.00	\$750.00	\$300.00	\$300.00
39	Valve Box, Adj	Ea	2	\$750.00	\$1,500.00	\$389.00	\$778.00	\$550.00	\$1,100.00	\$950.00	\$1,900.00	\$500.00	\$1,000.00	\$400.00	\$800.00
40	Water Main Conflict	Ea	1	\$2,500.00	\$2,500.00	\$3,829.00	\$3,829.00	\$4,800.00	\$4,800.00	\$2,500.00	\$2,500.00	\$3,000.00	\$3,000.00	\$3,000.00	\$3,000.00
41	Sprinkler Repair Allowance, Max \$5,000	Dir	5,000	\$1.00	\$5,000.00	\$1.00	\$5,000.00	\$1.00	\$5,000.00	\$1.00	\$5,000.00	\$1.00	\$5,000.00	\$0.50	\$2,500.00
TOTAL ALL ITEMS					\$661,750.00		\$498,138.65		\$542,623.20		\$551,440.00		\$584,958.00		\$610,272.50



May 15, 2024

Re: Royal Oak and Eastland Road
Improvements
Project No. 240129.01

Mr. Jared Olson, City Manager
City of Roosevelt Park
900 Oak Ridge Road
Muskegon, Michigan 49441

Dear Mr. Olson:

Based on our recommendation to award a contract on the **Royal Oak and Eastland Improvements** project in the amount of \$498,138.65, we hereby estimate the total project budget as follows:

PROJECT COSTS

Low Bid (Jackson-Merkey Contractors)	\$498,138.65
Design Engineering	\$33,000.00
Construction Inspection and Engineering	\$47,500.00
Project Contingencies	\$49,361.35
	<hr/>

TOTAL ESTIMATED BUDGET **\$628,000.00**

Funding for the project is provided by an MDOT Category B grant along with a local match from the City.

If you have any questions, please contact me.

Sincerely,

Ryan M. Arends, P.E.
Project Engineer

RMA/pim

cc. Ben VanHoeven, DPW Superintendent



CITY OF ROOSEVELT PARK

MUSKEGON CO., MICHIGAN

ROYAL OAK ROAD AND EASTLAND ROAD

IMPROVEMENTS

FROM ROOSEVELT RD TO GLENSIDE BLVD

PLAN INDEX

SHEET NO.	DESCRIPTION
1	TITLE SHEET
2	TYPICAL CROSS SECTIONS
3-5	REMOVALS
6-8	IMPROVEMENTS

-2024-

UTILITY COMPANIES

CONSUMERS ENERGY (ELECTRIC)
 PO BOX 201
 GRAND RAPIDS, MI 49501-0201
 (616) 530-4244

DTE ENERGY (NATURAL GAS)
 444 WEALTHY ST. SW
 GRAND RAPIDS, MI 49503
 (800) 947-5000

XFINITY/COMCAST (CABLE TV)
 955 CENTURY AVE. SW
 GRAND RAPIDS, MI 49503
 (616) 245-5039

ROOSEVELT PARK (WATER)
 900 OAK RIDGE RD.
 MUSKEGON, MI 49441
 (231) 755-3721

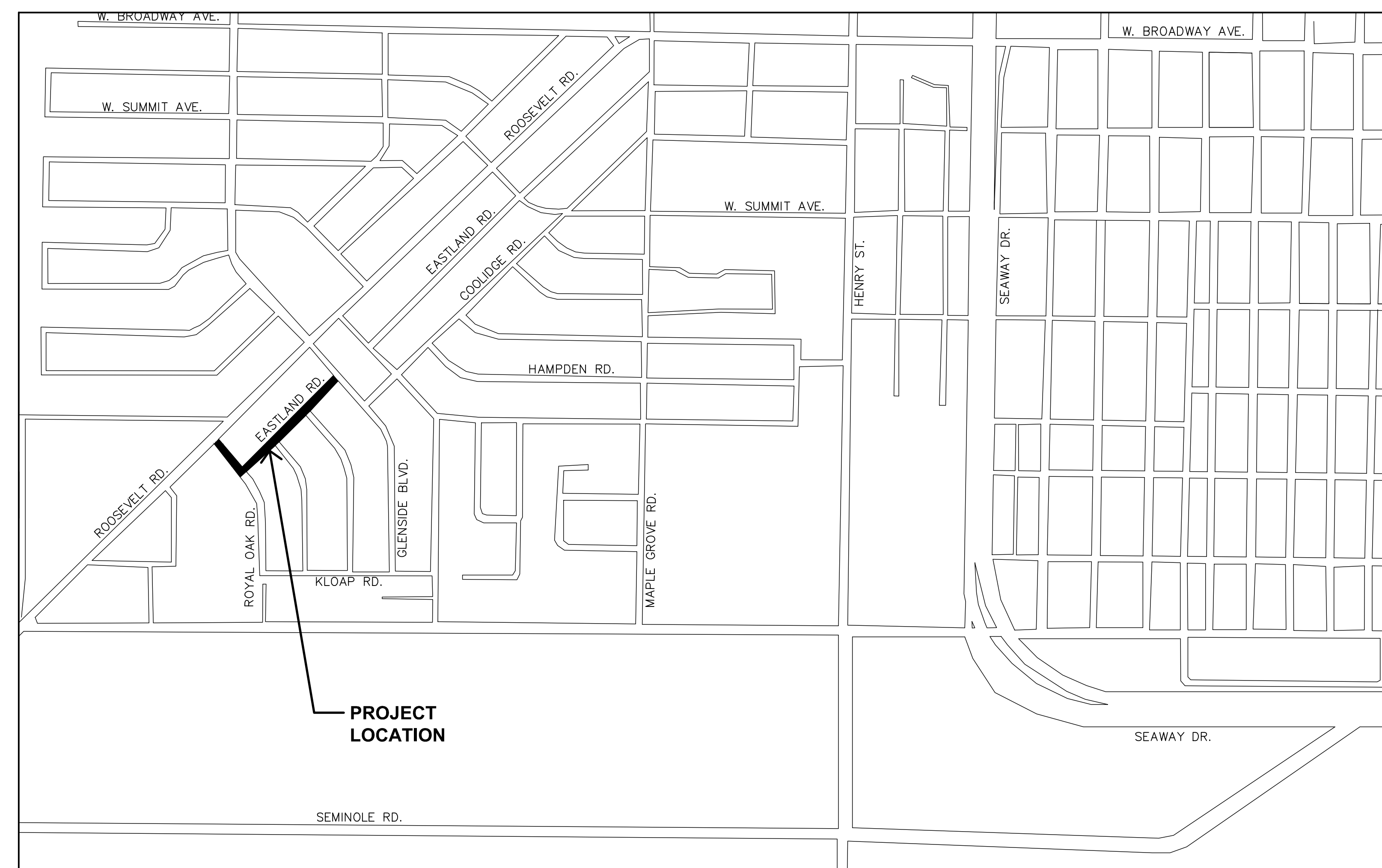

PROJECT LOCATION MAP

PROJECT DESCRIPTION: ROAD RECONSTRUCTION IN ROYAL OAK ROAD AND EASTLAND ROAD INCLUDING STORM SEWER, AGGREGATE BASE, CONCRETE CURB AND GUTTER AT INTERSECTIONS AND HMA RESURFACING.

ROYAL OAK ROAD AND EASTLAND ROAD IMPROVEMENTS
 FROM ROOSEVELT RD TO GLENSIDE BLVD

SURVEYED & DESIGNED BY:

Moore+Bruggink
 Consulting Engineers
 2020 Monroe Ave.
 Grand Rapids, MI 49505
 (616) 363-9801 mailbox@mbce.com

CITY OF ROOSEVELT PARK APPROVAL

Jared D. Olson
 JAROD OLSON, CITY MANAGER

April 9, 2024
 DATE

PREPARED UNDER SUPERVISION OF
 RYAN MICHAEL ARENDS P.E.
 ENGINEER, P.E.

6201056998
 REGISTRATION NO.

Moore+Bruggink
 ORGANIZATION

2020 MONROE NW GRAND RAPIDS, MI 49505
 ADDRESS



P:\240129_01_Royal Oak and Eastland Road Improvements\CAD\DWG\240129_01_COVER SHEET.dwg 4/3/2024 11:29:35 AM JAMES VANHEKKEN

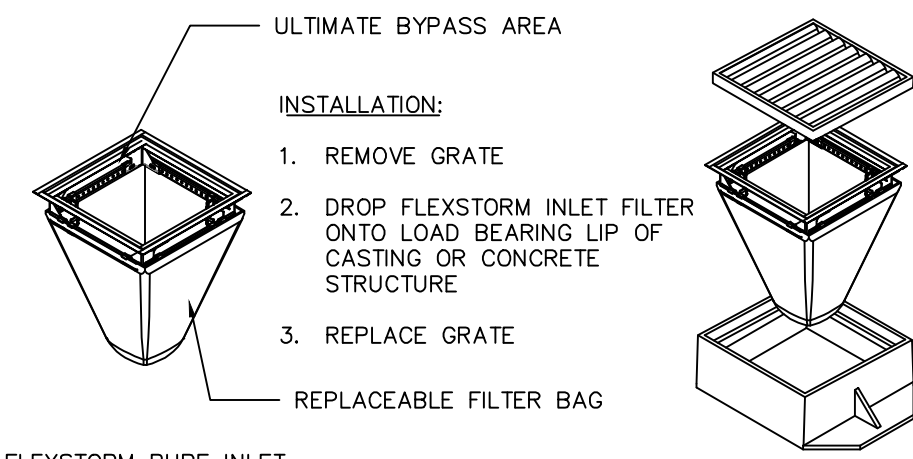

FLEXSTORM PURE INLET FILTERS FOR RECTANGULAR OPENINGS WITH GRATES

NOTES:

1. ALL FRAMING IS CONSTRUCTED OF 304 STAINLESS STEEL FOR 25 YEAR SERVICE LIFE RATING
2. TOTAL BYPASS CAPACITY: BYPASS CAPACITY WILL VARY WITH EACH SIZE DRAINAGE STRUCTURE. FLEXSTORM DESIGNS FRAMING BYPASS TO MEET OR EXCEED THE DESIGN FLOW OF THE PARTICULAR DRAINAGE STRUCTURE.
3. UPON ORDERING CONFIRMATION OF THE DOT CALLOUT, PRECAST OR CASTING MAKE AND MODEL, OR DETAILED DIMENSIONAL FORMS MUST BE PROVIDED TO CONFIGURE AND ASSEMBLE YOUR CUSTOMIZED FLEXSTORM INLET FILTER. PART NUMBER ALONE IS NOT SUFFICIENT.
4. FOR WRITTEN SPECIFICATIONS AND MAINTENANCE GUIDELINES VISIT WWW.INLETFILTERS.COM

INLET PROTECTION DETAIL

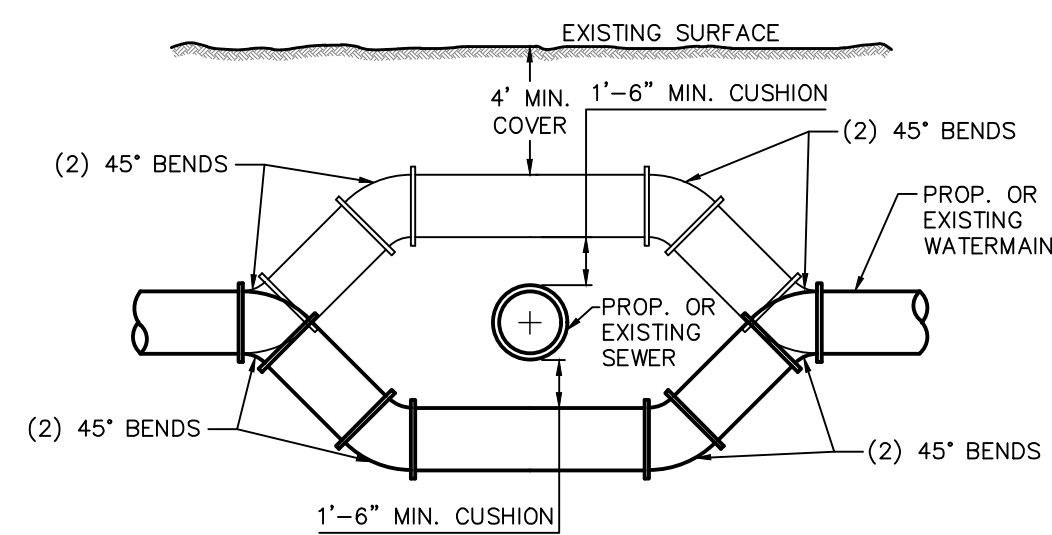

NOTE:

1. WHEN MINIMUM CLEARANCE AND COVER CANNOT BE OBTAINED, THE WATERMAIN IS TO BE OFFSET UNDER THE SEWER.
2. JOINT RESTRAINT SHALL BE OBTAINED BY MEGA LUG CONNECTIONS

WATERMAIN OFFSET DETAIL

SCALE: 1"=6"

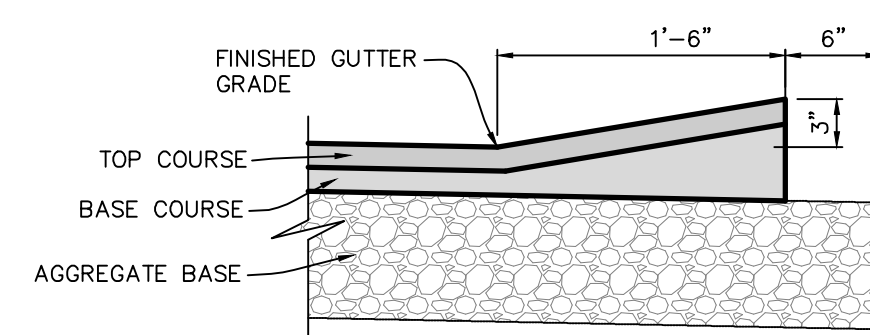

18" BITUMINOUS VALLEY GUTTER DETAIL
SCALE: 1"=1'

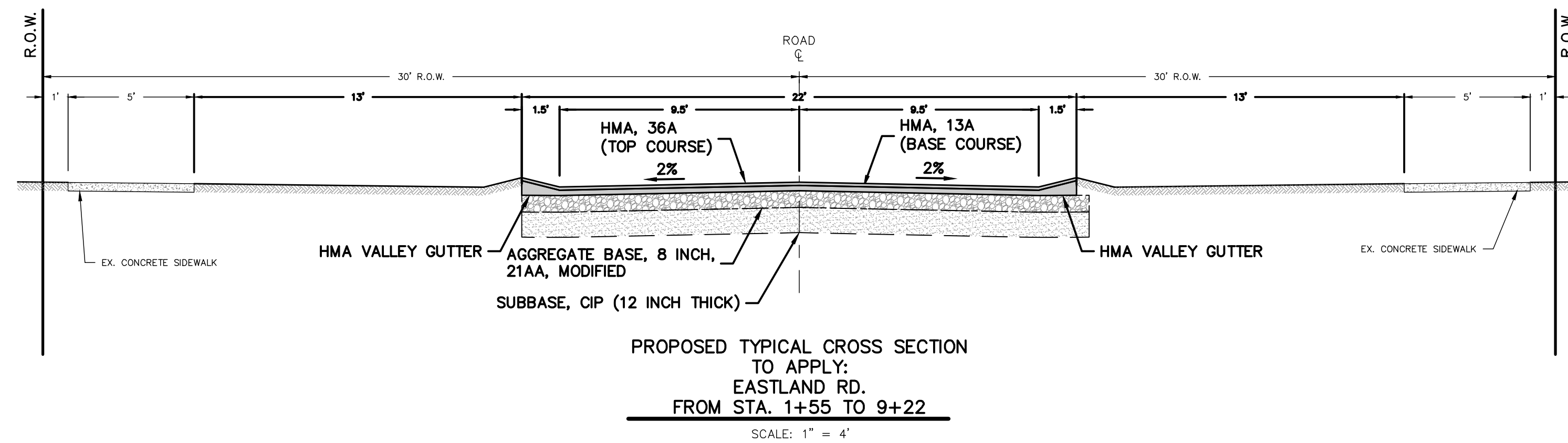
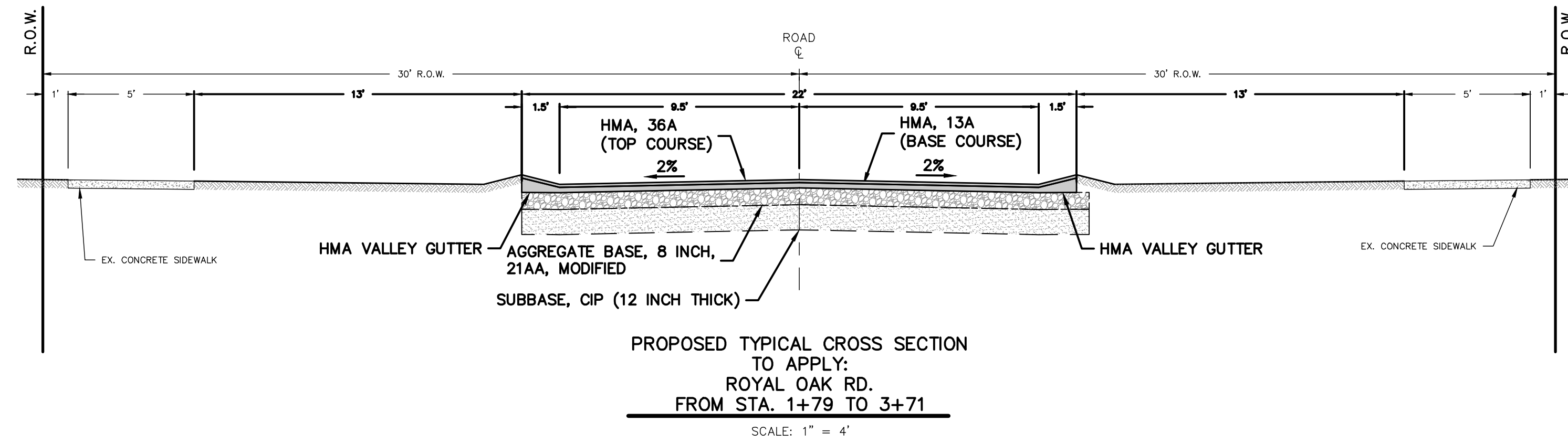
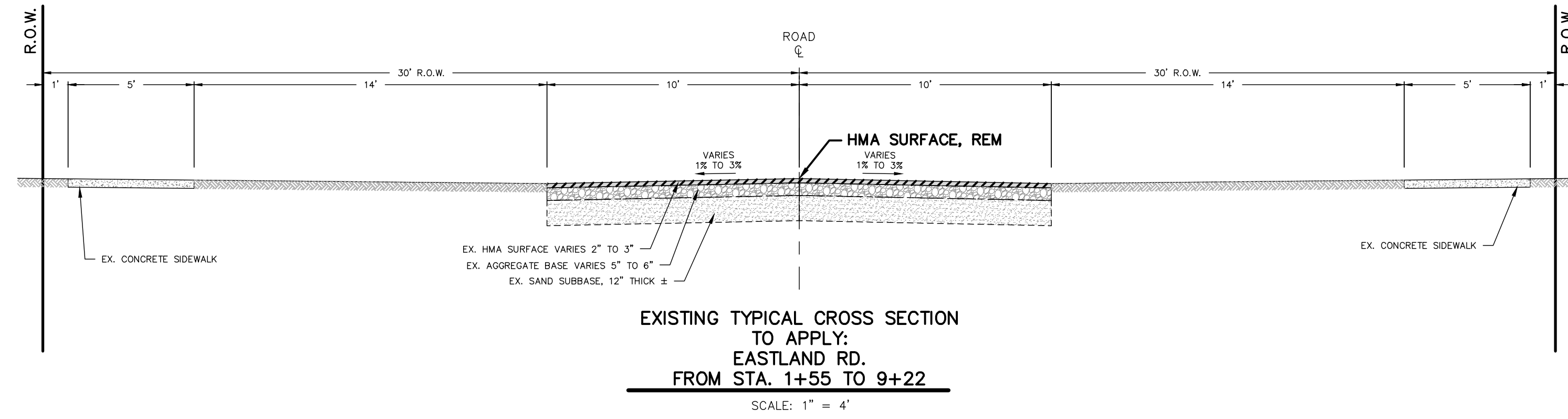
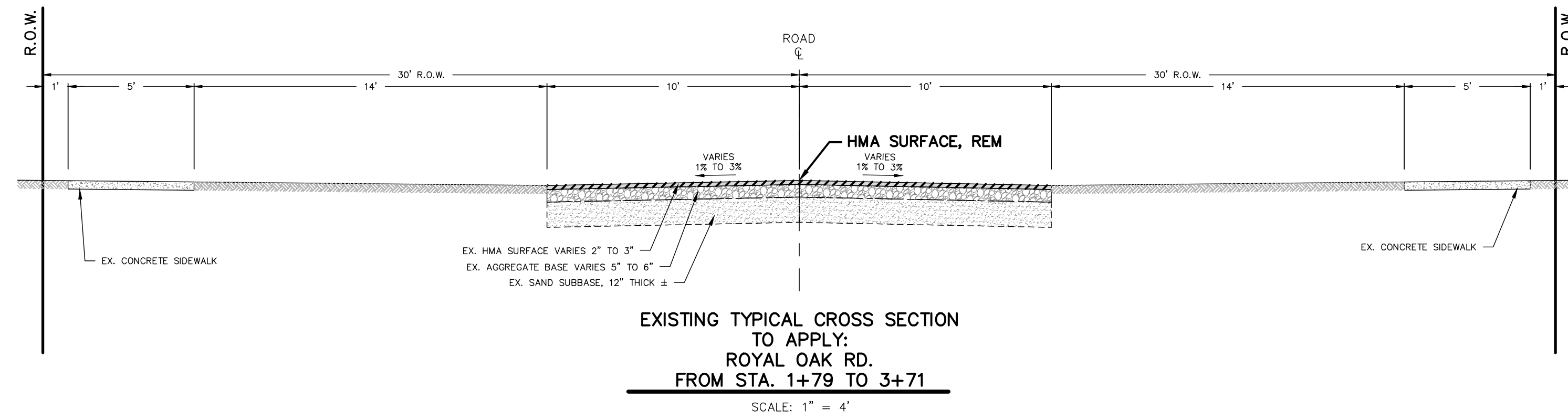

HMA APPLICATION TABLE

MIX ID	ITEM	RATE (LBS/SYD)	ASPHALT PERFORMANCE GRADE	REMARKS	AGGREGATE WORK INDEX
HMA, 36A	HMA, 36A	165 (1 1/2 INCHES)	PG 58-28	TOP COURSE	AWI-220 MIN.
HMA, 13A	HMA, 13A	275 (2 1/2 INCHES)	PG 58-28	LEVELING COURSE	
HAND PATCHING, HMA, 13A	HAND PATCHING	275 (1 1/2 INCHES)	PG 58-28		
HMA, 36A	HMA APPROACH	330 (3 INCHES)	PG 58-28	PLACED IN TWO EQUAL LIFTS	

P:\240129.01 Royal Oak and Eastland Road Improvements\CAD\DWG\240129_CROSS SECTIONS.dwg, 4/3/2024, 11:29:40 AM, JAMES VANHEKKE

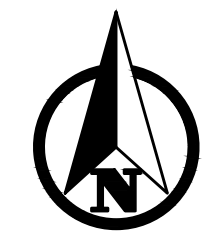

0 2 4
PLAN SCALE: 1" = 4'



PLAN REVISIONS

Moore+Bruggink
Consulting Engineers
2020 Monroe Ave.
Grand Rapids, MI 49505
(616) 363-9801
mailto:mail@mbce.com



TYPICAL CROSS SECTIONS

IN
ROYAL OAK ROAD AND EASTLAND ROAD
FROM ROOSEVELT RD TO EASTLAND RD
CITY OF ROOSEVELT PARK, MUSKOGON CO., MICHIGAN

FIELD SURVEY / DATE
M+B
PROJECT NO. 240129.01
DESIGN DRAWN BY: JPV
DESIGNED BY: RMA
CHECKED BY: AP
PLAN DATE: APRIL 17, 2024

SHEET NUMBER
2 OF 8

BENCHMARKS - NAVD88
 ELEVATION - 618.772
 THE SOUTHEAST CORNER OF A 1' BY 4' CONC
 BOTTOM STEP(0.5'- ABOVE CONC) ON THE
 NORTHEAST SIDE OF HOUSE #3219 ROYAL OAK RD

CONTROL POINTS - MI SOUTH SPCS NAD83

CP#1	CP#2
M+B RED CAP	M+B RED CAP
N 623226.8166	N 622981.4390
E 12613497.3629	E 12613701.7547
ELEV 618.290	ELEV 616.322

SOIL BORING NO.	DEPTH	DESCRIPTION
SB-1	0.00' TO 0.17'	HMA (HOT MIX ASPHALT)
	0.17' TO 0.67'	SAND - FINE TO COARSE WITH NATURAL GRAVEL - BROWN, SILTY
	0.67' TO 2.00'	SAND - DARK BROWN, SILTY
	2.00' TO 10.00'	FINE TO MEDIUM SAND - LIGHT BROWN
		END OF BORING
		NO GROUNDWATER ENCOUNTERED

REMOVAL LEGEND

	LIMITS OF HMA SURFACE, REM
	PAVT, REM & SIDEWALK REM
X	REMOVE CURB & GUTTER
	DRAINAGE STRUCTURE ADJUST
	REMOVE ITEM

0 10 20
 PLAN SCALE: 1" = 20'
 PROFILE SCALES:
 HORIZ: 1" = 30'
 VERT: 1" = 5'

811
 Know what's below.
 Call before you dig.

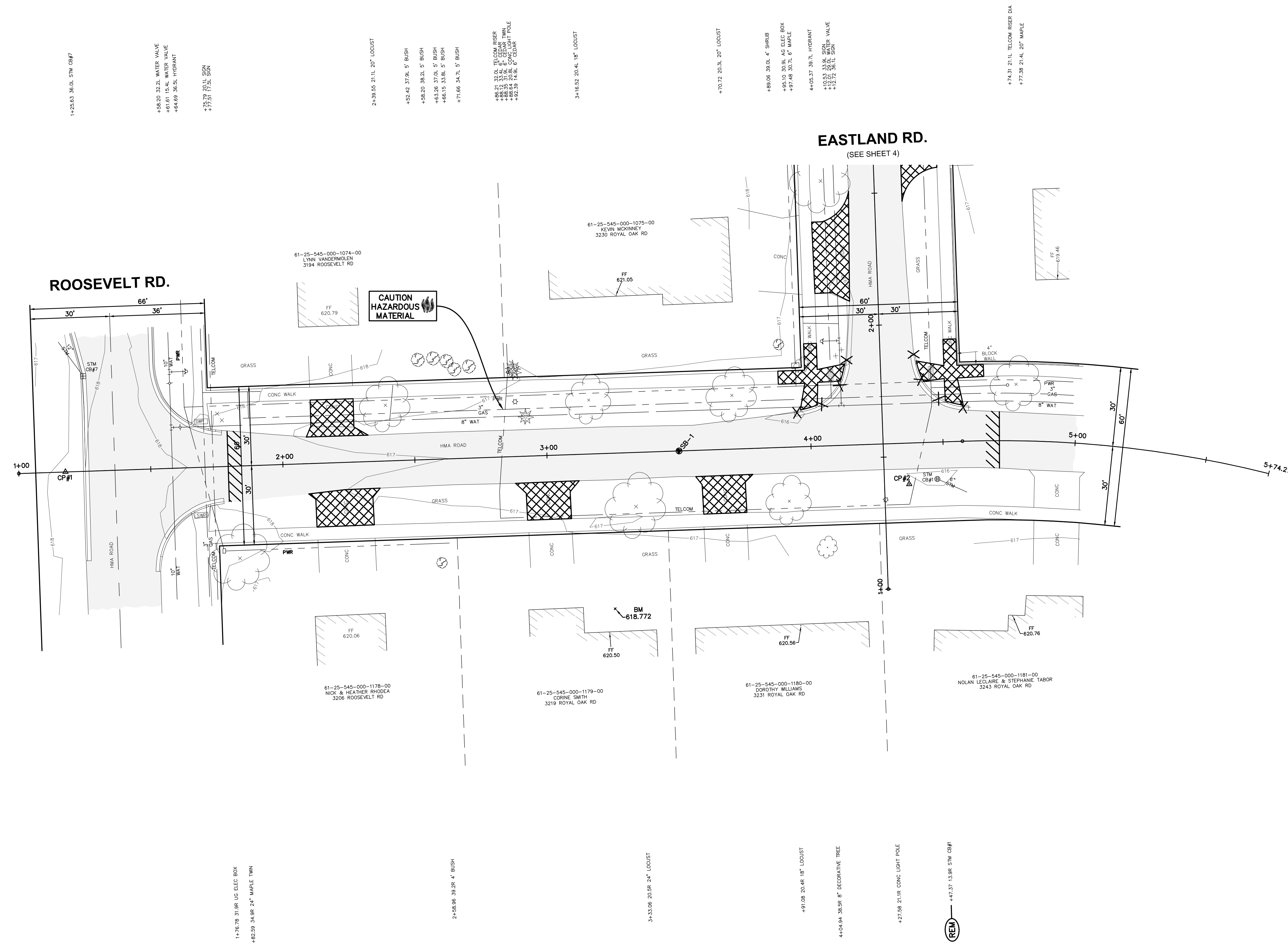

PLAN REVISIONS

Moore+Bruggink
 Consulting Engineers
 2020 Monroe Ave.
 Grand Rapids, MI 49505
 (616) 365-9801 mailbox@mbce.com

REMOVALS
 IN
ROYAL OAK ROAD
 FROM ROOSEVELT RD TO EASTLAND RD
 CITY OF ROOSEVELT PARK, MUSKEGON CO., MICHIGAN

FIELD SURVEY / DATE	M+B
PROJECT NO.	240129.01
DESIGN DRAWN BY:	JPV
DESIGNED BY:	RMA
CHECKED BY:	AP
PLAN DATE:	APRIL 17, 2024
SHEET NUMBER	3 OF 8

BENCHMARKS - NAVD88

ELEVATION - 618.772
 THE SOUTHWEST CORNER OF A 1' BY 4' CONC
 BOTTOM STEP (0.5' ABOVE CONC) ON THE
 NORTHEAST SIDE OF HOUSE #3219 ROYAL OAK RD

ELEVATION - 619.291
 THE SOUTHWEST CORNER OF A 1' BY 5' CONC
 BOTTOM STEP (0.7' ABOVE CONC) LOCATED ON THE
 SOUTHWEST SIDE OF HOUSE #3197 EASTLAND RD

CONTROL POINTS - MI SOUTH SPCS NAD83

CP #2	CP #3
M+B RED CAP	M+B RED CAP
N 622981.4390	N 623158.6688
E 12613701.7547	E 12613912.3911
ELEV 616.322	ELEV 616.852

SOIL BORING NO.	DEPTH	DESCRIPTION
SB-1	0.00' TO 0.17'	HMA (HOT MIX ASPHALT)
	0.17' TO 0.67'	SAND - FINE TO COARSE WITH NATURAL GRAVEL - BROWN, SILTY
	0.67' TO 2.00'	SAND - DARK BROWN, SILTY
	2.00' TO 10.00'	FINE TO MEDIUM SAND - LIGHT BROWN
		END OF BORING
		NO GROUNDWATER ENCOUNTERED

REMOVAL LEGEND

	LIMITS OF HMA SURFACE, REM
	PAVT, REM & SIDEWALK REM
	REMOVE CURB & GUTTER
	DRAINAGE STRUCTURE ADJUST VALVE BOX ADJUST

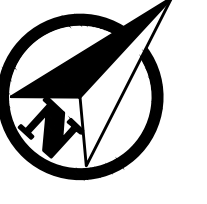

0 10 20
 PLAN SCALE: 1" = 20'
 PROFILE SCALE: 1" = 20'
 VERT: 1" = 5'



Know what's below.
 Call before you dig.

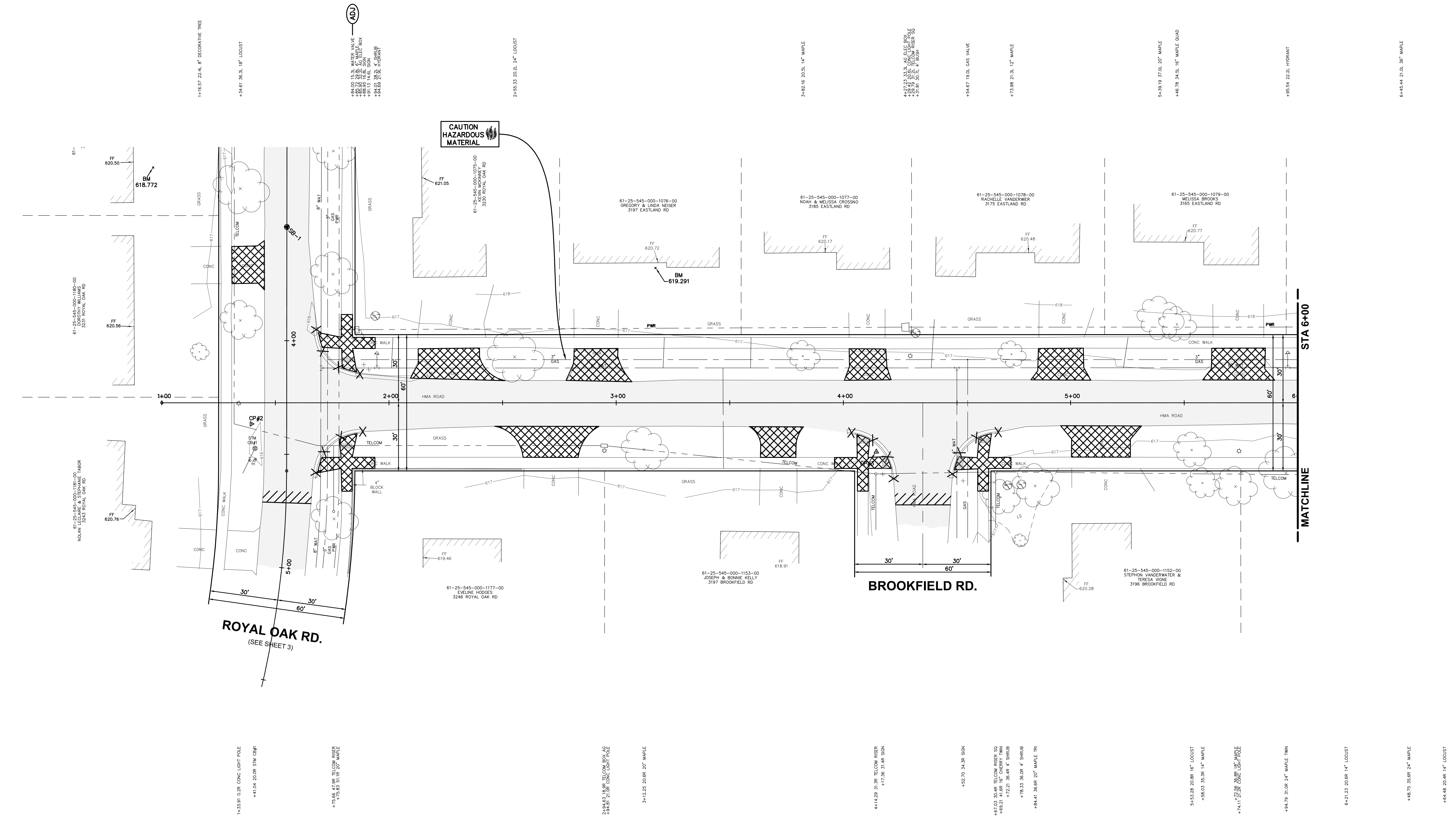

PLAN REVISIONS

Moore+Bruggink
 Consulting Engineers
 2020 Monroe Ave.
 Grand Rapids, MI 49505
 (616) 365-9801
 mailbox@mcbce.com

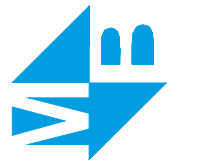

REMOVALS IN EASTLAND ROAD
 FROM ROYAL OAK RD TO GLENSIDE BLVD
 CITY OF ROOSEVELT PARK, MUSKEGON CO., MICHIGAN

FIELD SURVEY / DATE	M+B
PROJECT NO.	240129.01
DESIGN DRAWN BY:	JBV
DESIGNED BY:	RMA
CHECKED BY:	AP
PLAN DATE:	APRIL 17, 2024

BENCHMARKS - NAVD88
 ELEVATION - 619.257
 THE SOUTHEAST CORNER OF A 4' BY 30' CONC FRONT PATIO (0.6± ABOVE CONC) TO HOUSE #3133 EASTLAND RD
 ELEVATION - 619.245
 THE SOUTHWEST CORNER OF A 9' BY 5.5' CONC FRONT PATIO (0.6± ABOVE CONC) TO HOUSE #3147 EASTLAND RD

SOIL BORING NO.	DEPTH	DESCRIPTION
98-2	0.00' TO 0.17'	HMA (HOT MIX ASPHALT)
	0.17' TO 0.58'	SAND - FINE TO COARSE WITH NATURAL GRAVEL AND SILT - BROWN
	0.58' TO 0.92'	FINE TO MEDIUM SAND - GRAY
	0.92' TO 2.50'	FINE TO MEDIUM SAND - BROWN, SILTY
	2.50' TO 10.00'	FINE TO MEDIUM SAND - LIGHT BROWN
		END OF BORING
		NO GROUNDWATER ENCOUNTERED

CONTROL POINTS - MI SOUTH SPCS NAD83
 CP#4
 M+5 RED CAP
 N 623394.1059
 E 1261405.6910
 ELEV 617.611
 CP#5
 M+5 RED CAP
 N 623601.4478
 E 12614391.7014
 ELEV 618.180

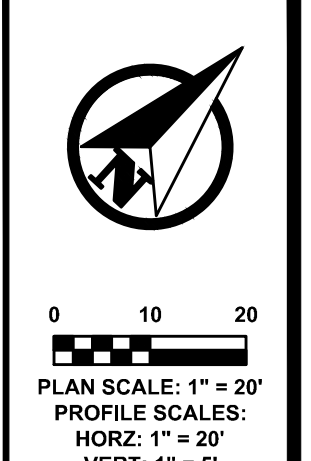
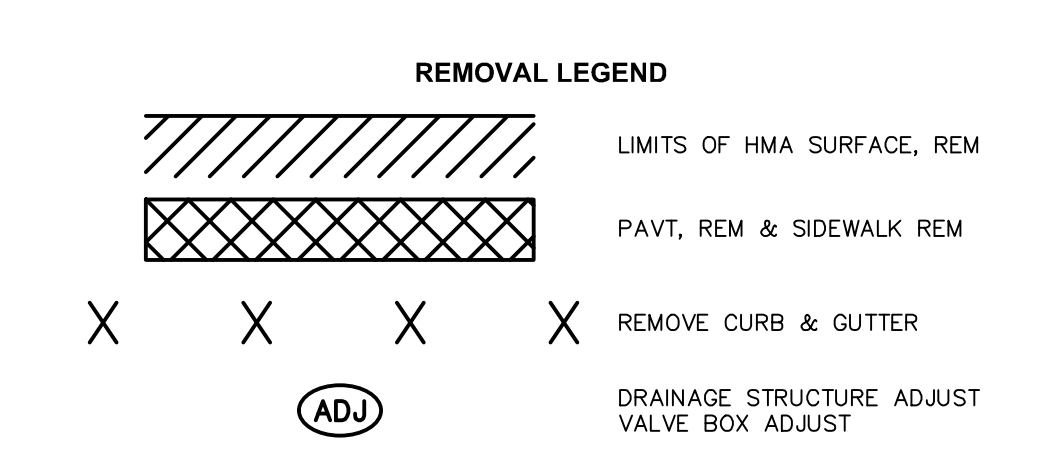

5+39.19 37.0L 20" MAPLE
 +46.78 34.5L 16" MAPLE QUAD
 +95.54 22.2L HYDRANT

6+45.44 31.0L 30" MAPLE
 +84.72 21.5L 18" MAPLE
 7+49.29 33.4L 4L ELEC POLE
 +40.00 22.0L TELECOM RESER * DA
 +40.00 22.0L TELECOM RESER * DA

8+53.11 20.0L 20" MAPLE
 9+44.36 20.4L 24" MAPLE
 +48.38 24.6L 24" MAPLE

10+04.69 22.8L HYDRANT
 +13.77 15.6L WATER VALVE
 +31.27 38.8L STM CSR#
 +43.03 33.5L STM MH#4

+59.30 12.2L STM CSR#
 +87.72 6.1L SON
 +73.21 26.5L 20" LOCUST

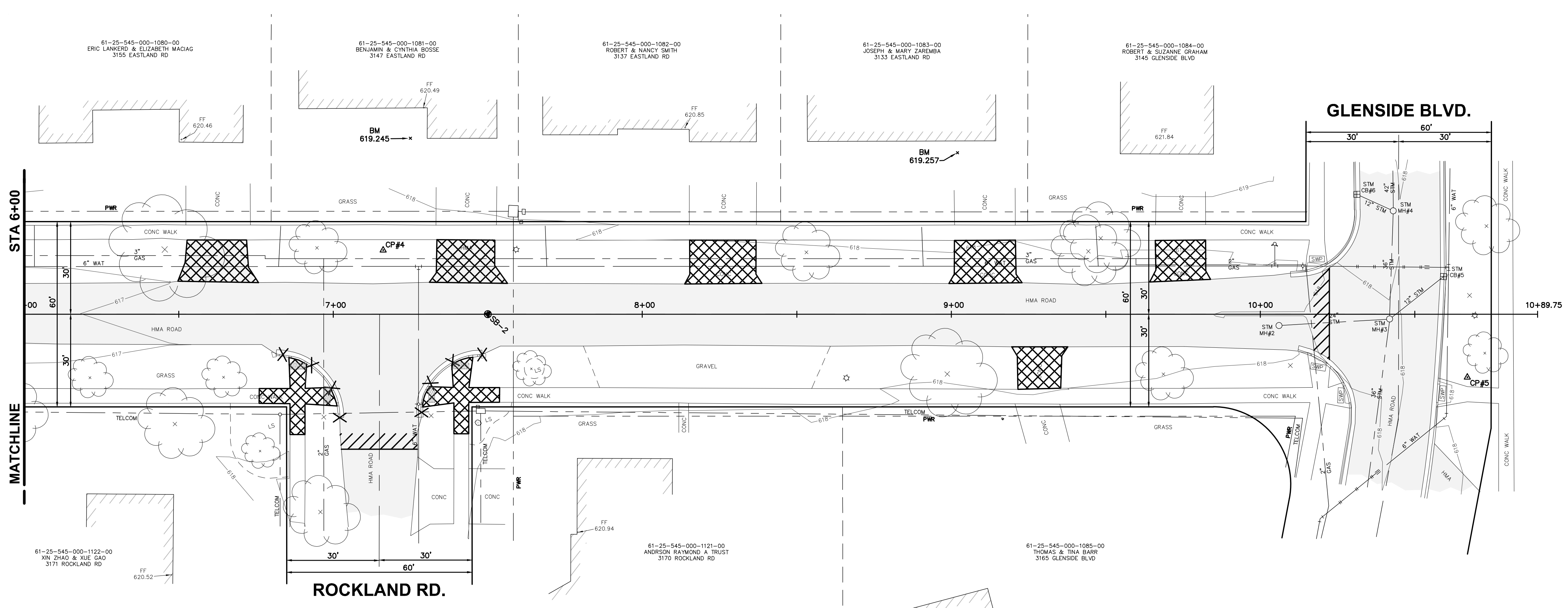

P:\240129\01 Royal Oak and Eastland Road Improvements\CAD\DWG\240129_Eastland_Sheets.dwg 4/3/2024 11:30:04 AM JAMES VANHEKKEN

5+53.28 20.8R 16" LOCUST
 +58.03 35.3R 14" MAPLE
 +74.17 34.8R 18" MAPLE
 +94.79 31.0R 24" MAPLE TRN

6+21.23 20.6R 14" LOCUST
 +48.75 35.6R 24" MAPLE
 +54.48 20.4R 14" LOCUST
 +76.30 44.3R 12" MAPLE QUAD
 +82.75 32.4R TELECOM RESER * DA
 +96.95 33.3R SON

7+27.60 29.1R WATER VALVE
 +31.66 32.8R SON
 +46.76 30.9R TELECOM RESER * DA
 +47.75 31.3R TELECOM RESER * DA
 +44.09 17.7R 12" MAPLE

8+66.05 20.8R CONC LIGHT POLE
 +88.71 19.4R 30" MAPLE
 9+16.57 33.8R VMSD LIGHT
 +68.08 19.4R 18" MAPLE

10+106.06 3.7R STM MH#2
 +207.73 16.6R SON
 +41.86 1.5R STM MH#3
 +69.46 0.4R CONC LIGHT POLE
 +72.67 12.8R 14" MAPLE

PLAN REVISIONS

Moore+Bruggink
 Consulting Engineers
 2020 Monroe Ave.
 Grand Rapids, MI 49505
 (616) 365-9801 mailbox@mbce.com

REMOVALS IN EASTLAND ROAD
 FROM ROYAL OAK RD TO GLENSIDE BLVD
 CITY OF ROOSEVELT PARK, MUSKEGON CO., MICHIGAN

FIELD SURVEY / DATE
 M+B
 PROJECT NO. 240129.01
 DESIGN DRAWN BY: JBV
 DESIGNED BY: RMA
 CHECKED BY: AP
 PLAN DATE: APRIL 17, 2024
 SHEET NUMBER
5 OF 8

BENCHMARKS - NAVD88
 ELEVATION - 618.772
 THE SOUTHEAST CORNER OF A 1' BY 4' CONC
 BOTTOM STEP(0.5ft ABOVE CONC) ON THE
 NORTHEAST SIDE OF HOUSE #3219 ROYAL OAK RD

CONTROL POINTS - MI SOUTH SPCS NAD83

CP#1	CP#2
M+8 RED CAP	M+8 RED CAP
N 623226.8166	N 622981.4390
E 12613497.3629	E 12613701.7547
ELEV 618.290	ELEV 616.322

SOL. BORING NO.	DEPTH	DESCRIPTION
SB-1	0.00' TO 0.17'	HMA (HOT MIX ASPHALT)
	0.17' TO 0.67'	SAND - FINE TO COARSE WITH NATURAL GRAVEL - BROWN, SILTY
	0.67' TO 2.00'	SAND - DARK BROWN, SILTY
	2.00' TO 10.00'	FINE TO MEDIUM SAND - LIGHT BROWN
		END OF BORING
		NO GROUNDWATER ENCOUNTERED

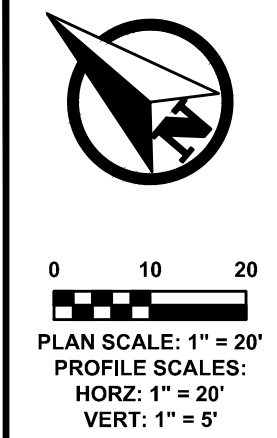
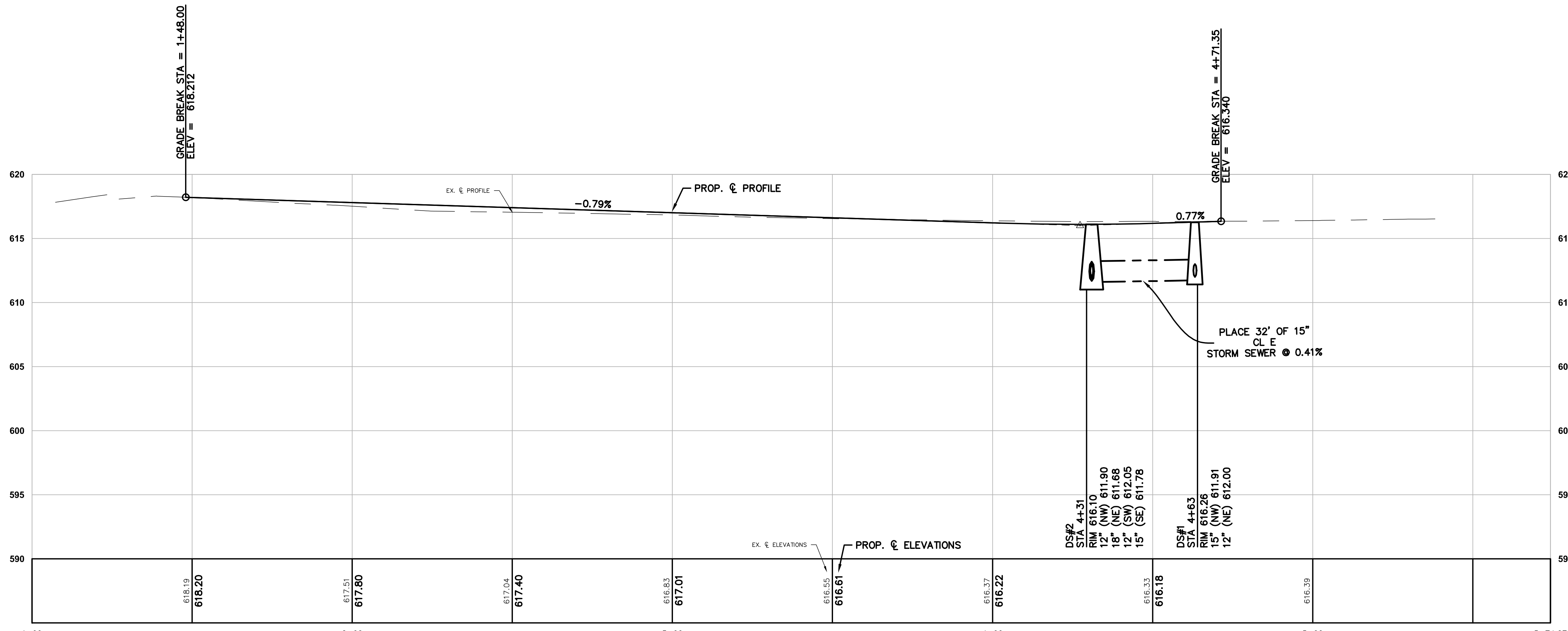
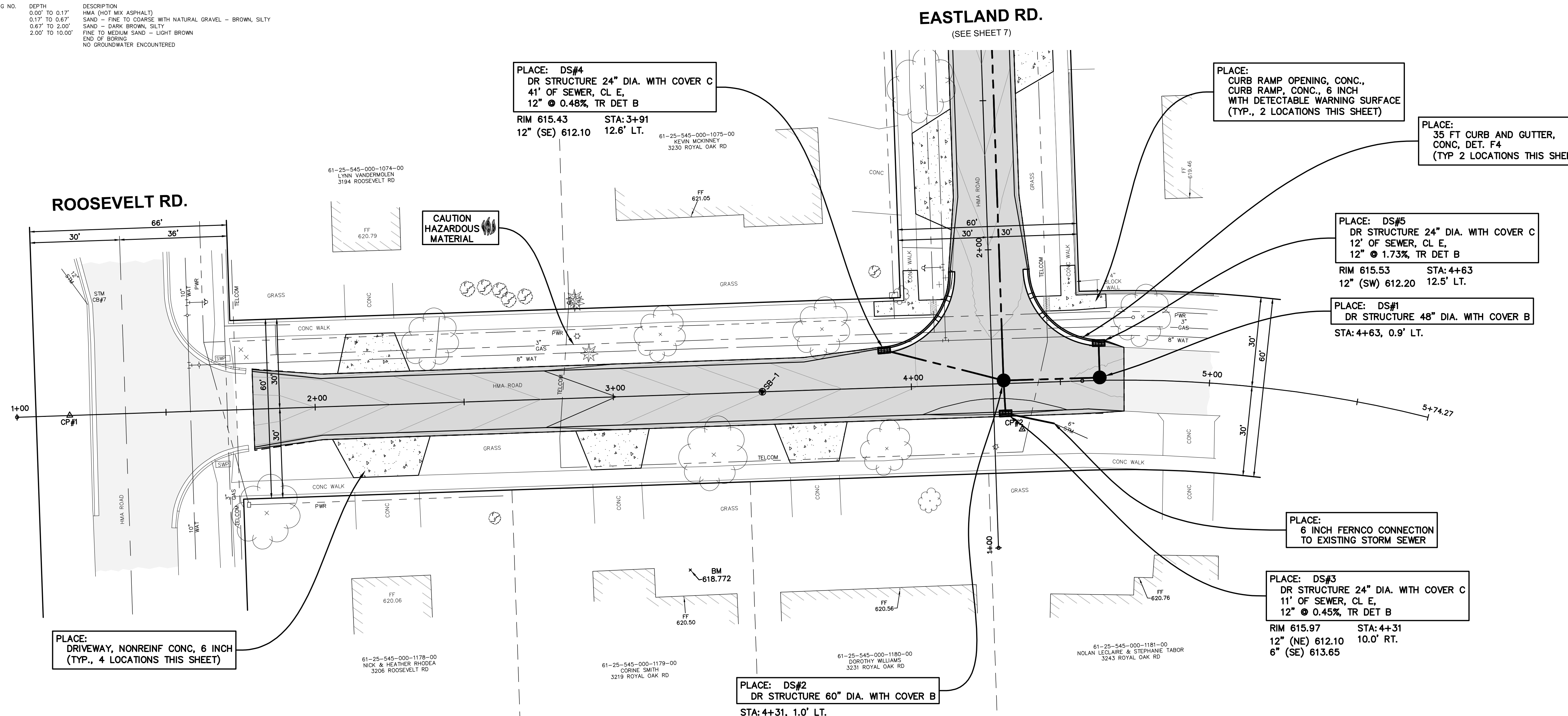

PLAN REVISIONS

P:\240129.01 Royal Oak and Eastland Road Improvements\CAD\DWG\240129 ROYAL OAK GRADING SHEETS.dwg, 4/3/2024 11:30:14 AM, JAMES VANHEKKE

Moore+Bruggink
 Consulting Engineers
 2020 Monroe Ave.
 Grand Rapids, MI 49505
 (616) 365-9801 mailbox@mbrace.com

IMPROVEMENTS
 IN
ROYAL OAK ROAD
 FROM ROOSEVELT RD TO EASTLAND RD
 CITY OF ROOSEVELT PARK, MUSKEGON CO., MICHIGAN

FIELD SURVEY / DATE	M+B
PROJECT NO.	240129.01
DESIGN DRAWN BY:	JPV
DESIGNED BY:	RMA
CHECKED BY:	AP
PLAN DATE:	APRIL 17, 2024
SHEET NUMBER	6 OF 8

P:\240129\01 Royal Oak and Eastland Road Improvements\CAD\DWG\240129\01 EASTLAND GRADING SHEETS.dwg, 4/3/2024 11:30:26 AM, JAMES VANHEKKEN

BENCHMARKS - NAVD88
 ELEVATION - 618.772
 THE SOUTHEAST CORNER OF A 1' BY 4' CONC
 BOTTOM STEP (0.5' ABOVE CONC) ON THE
 NORTHEAST SIDE OF HOUSE #3219 ROYAL OAK RD

ELEVATION - 619.291
 THE SOUTHWEST CORNER OF A 1' BY 5' CONC
 BOTTOM STEP (0.7' ABOVE CONC) LOCATED ON THE
 SOUTHEAST SIDE OF HOUSE #3197 EASTLAND RD

CONTROL POINTS - MI SOUTH SPCS NAD83

CP#2	CP#3
M+B RED CAP	M+B RED CAP
N 622981.4390	N 623158.6688
E 12613701.7547	E 12613912.3911
ELEV 616.322	ELEV 616.852

ROYAL OAK RD.
 (SEE SHEET 6)

SOIL BORING NO. SB-1
 DEPTH 0.00' TO 0.17'
 0.17' TO 0.67'
 0.67' TO 2.00'
 2.00' TO 10.00'

DESCRIPTION
 HMA (HOT MIX ASPHALT)
 SAND - FINE TO COARSE WITH NATURAL GRAVEL - BROWN, SILTY
 SAND - DARK BROWN, SILTY
 FINE TO MEDIUM SAND - LIGHT BROWN
 END OF BORING
 NO GROUNDWATER ENCOUNTERED

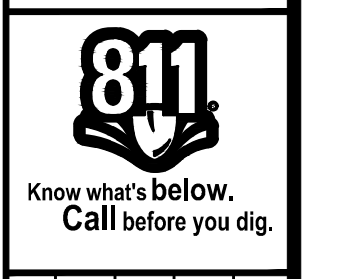
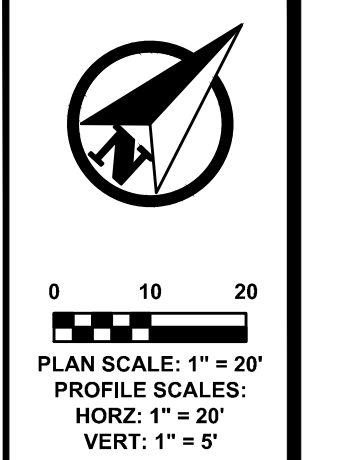
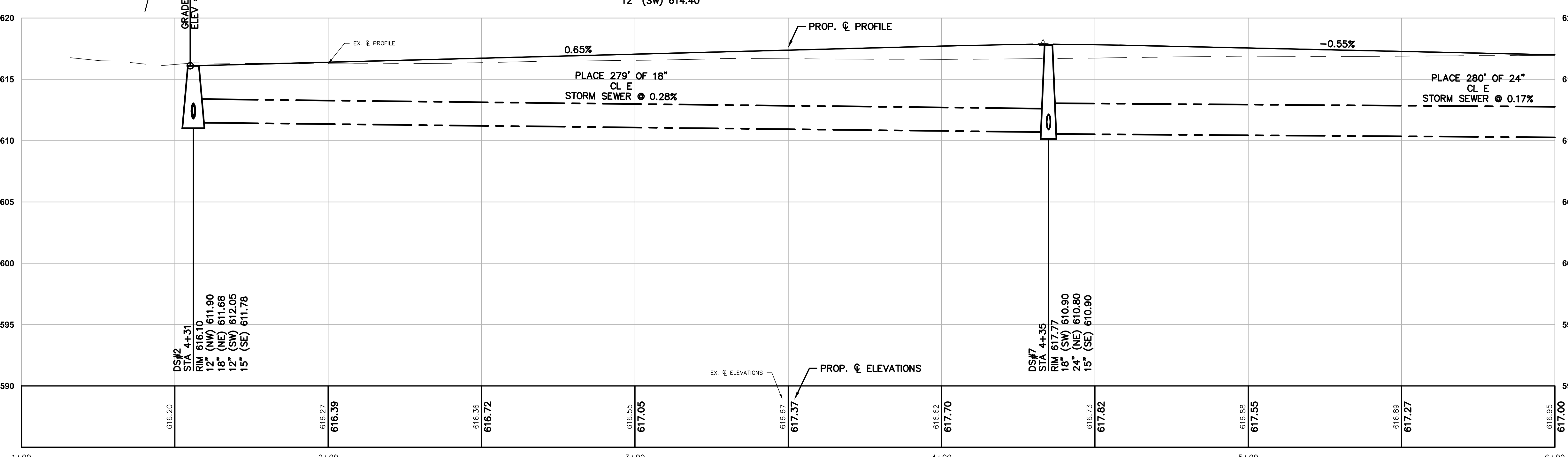
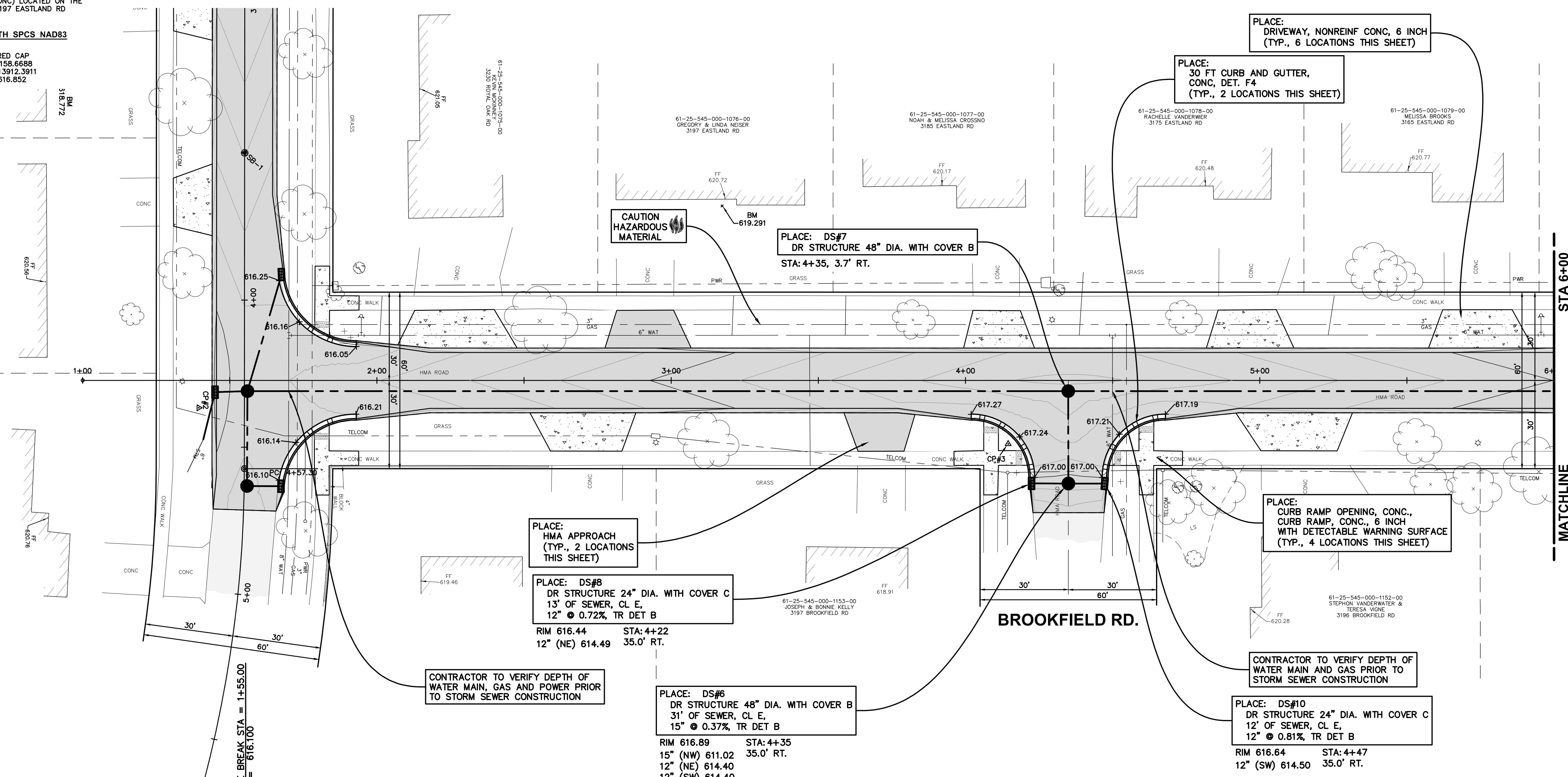

PLAN REVISIONS

Moore+Bruggink
 Consulting Engineers
 2020 Monroe Ave.
 Grand Rapids, MI 49505
 (616) 365-9801 | mailbox@mboe.com

IMPROVEMENTS IN EASTLAND ROAD
 FROM ROYAL OAK RD TO GLENSIDE BLVD
 CITY OF ROOSEVELT PARK, MUSKEGON CO., MICHIGAN

FIELD SURVEY / DATE	M+B
PROJECT NO.	240129.01
DESIGN DRAWN BY:	JPV
DESIGNED BY:	RMA
CHECKED BY:	AP
PLAN DATE:	APRIL 17, 2024
SHEET NUMBER	7 OF 8

BENCHMARKS - NAVD88
 ELEVATION - 619.257
 THE SOUTHEAST CORNER OF A 4' BY 30' CONC FRONT PATIO (0.6'± ABOVE CONC) TO HOUSE #3133 EASTLAND RD
 ELEVATION - 619.245
 THE SOUTHWEST CORNER OF A 9' BY 5.5' CONC FRONT PATIO (0.6'± ABOVE CONC) TO HOUSE #3147 EASTLAND RD

CONTROL POINTS - MI SOUTH SPCS NAD83
 CP#4 M+B RED CAP N 623394.1059 E 1261405.6910 ELEV 617.611
 CP#5 M+B RED CAP N 623601.4478 E 12614391.7014 ELEV 618.180

SOIL BORING NO. SB-2
 DEPTH DESCRIPTION
 0.00' TO 0.17' HMA (HOT MIX ASPHALT)
 0.17' TO 0.38' SAND - FINE TO COARSE
 0.38' TO 0.92' FINE TO MEDIUM SAND - GRAY
 0.92' TO 2.50' FINE TO MEDIUM SAND - BROWN, SILTY
 2.50' TO 10.00' FINE TO MEDIUM SAND - LIGHT BROWN
 END OF BORING
 NO GROUNDWATER ENCOUNTERED

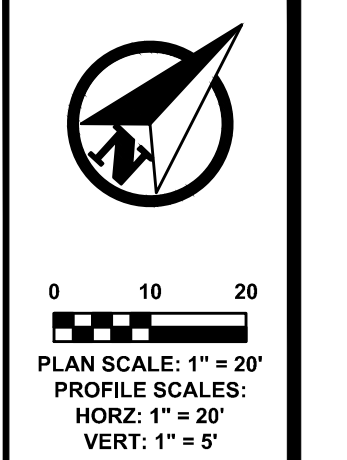
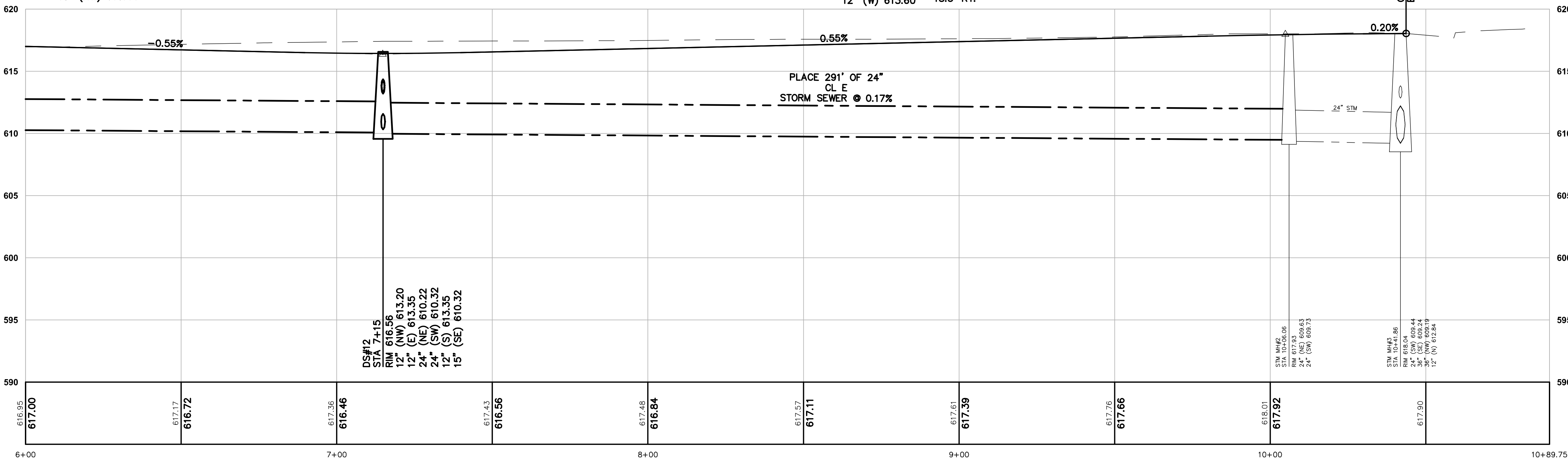
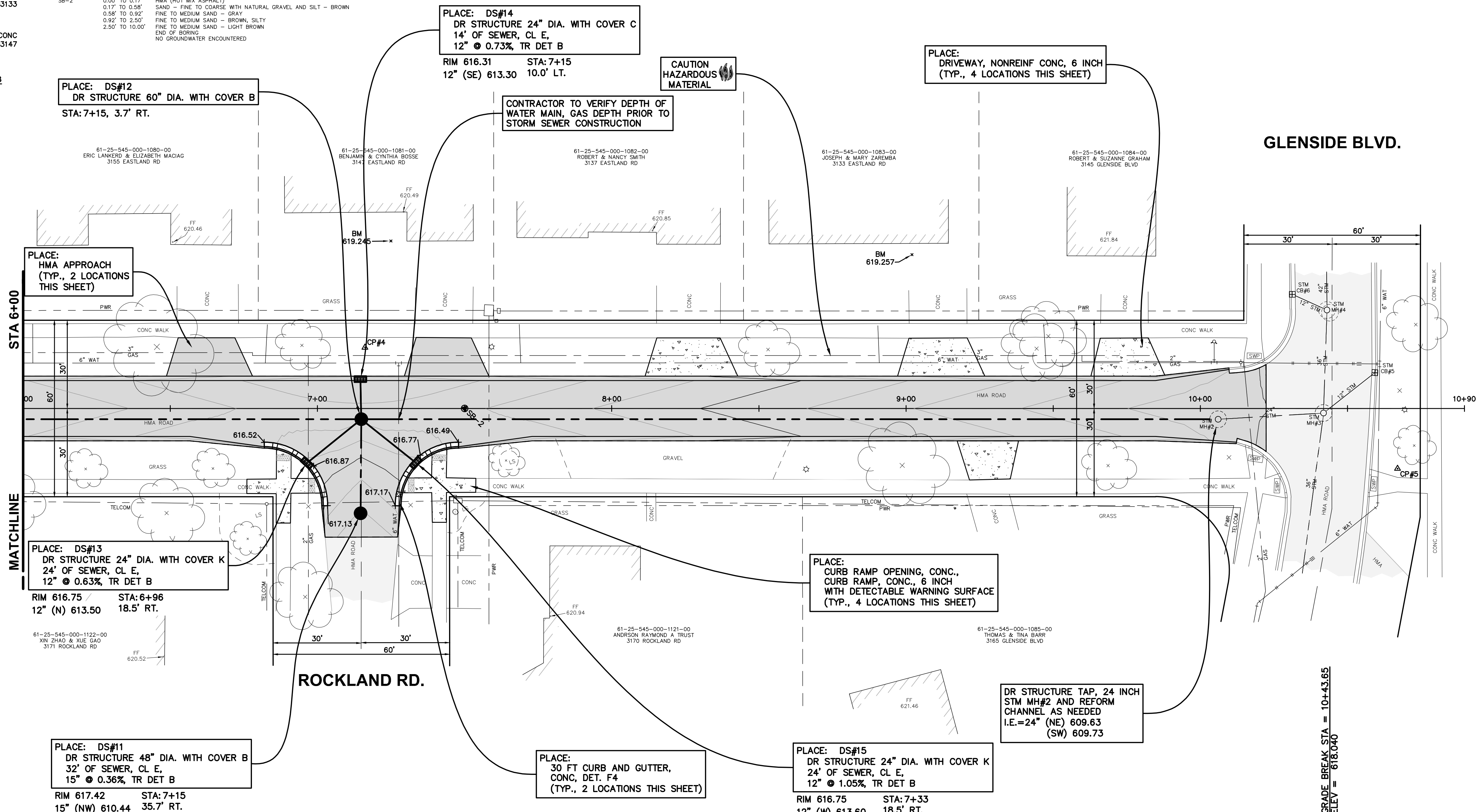

PLAN SCALE: 1" = 20'
 PROFILE SCALE: 1" = 20'
 HORIZ: 1" = 20'
 VERT: 1" = 5'

811
 Know what's below.
 Call before you dig.

PLAN REVISIONS

Moore+Bruggink
 Consulting Engineers
 2020 Monroe Ave.
 Grand Rapids, MI 49505
 (616) 365-9801 mailbox@mbrace.com

IMPROVEMENTS IN EASTLAND ROAD
 FROM ROOSEVELT RD TO EASTLAND RD
 CITY OF ROOSEVELT PARK, MUSKEGON CO., MICHIGAN

FIELD SURVEY / DATE: M+B
 PROJECT NO.: 240129.01
 DESIGN DRAWN BY: JPV
 DESIGNED BY: RMA
 CHECKED BY: AP
 PLAN DATE: APRIL 17, 2024
 SHEET NUMBER: 8 OF 8

P:\240129.01 Royal Oak and Eastland Road Improvements\CAD\DWG\240129.01_EASTLAND GRADING SHEETS.dwg 4.3.2024 11:30:29 AM_JAMES VANHEKKE



**CITY OF ROOSEVELT PARK
CITY COUNCIL MEETING
May 20, 2024**

Item: Set Roosevelt Park Day Meeting Time and Date	Date: May 20, 2024
As we continue the planning for the 2024 RP day event, the upcoming Roosevelt Park Day event planning discussion needs to continue. The next meeting date needs to be set and staff is recommending the week of June 3 rd or week of June 10 th .	
Financial Impact: None	
Recommendation: Set a committee meeting for the next Roosevelt Park Day event	
Signature:	Title: City Manager

City of Roosevelt Park

A Proud Community

Informational Updates

The following documents are informational updates and documents relating to our community. They are for your information only and no action is requested.

Inside208

Jump to...



Oath of Office Legislation Clears House Elections Committee

Posted on May 15, 2024 by Dave Hodgkins

Legislation that addresses a conflict between state law and some municipal charters cleared the House Elections Committee on Tuesday. As the result of Proposal 2 implementation, clerks must now account for ballots that come in six days following an election. As a result, municipalities with language in their charters requiring newly elected local officials to be seated the week following an election would be doing so prior to actual certification.

House Bills [5699](#), [5700](#), [5701](#), and [5702](#) would amend the Home Rule City Act, Home Rule Village Act, and Michigan Election Law to state that all terms of city, village, and township officers elected following December 31st of 2024 must not commence earlier than December 1st at noon going forward. This defaults those municipalities with earlier dates in their charters to December

The November 20th date in the General Law Village Act will also be amended to reflect December 1st moving forward. This legislation has no impact on municipalities with dates in their charters already after December 1st.

The League, with guidance from members, has been at the table negotiating language that solves the existing conflict while offering some flexibility to municipalities without mandating a change to charters. This language is a reflection of those conversations. MML took a position of neutral on the package.

The bills were voted out of committee with democrats all voting in favor and republicans passing. The legislation is now on the House floor.

Dave Hodgkins is a legislative associate with the League. He may be reached at dhodgkins@mml.org.

Contact

info@mml.org

734.662.3246



Norton Shores Fire Department

**QUARTERLY REPORT
ROOSEVELT PARK
January-March
2024**



Protecting Your Future



Administration

Chief Robert Gagnon

The information contained in this quarterly report serves as a representation of the hard work and dedication put in by the men and women of the Norton Shores Fire Department. Their commitment to the City and our Department helps to make it possible to achieve our overall mission which is *Protecting your Future.*

Quarterly Stats

- **749** Calls for Service the NSFD responded to
- **108** Calls for Service in Roosevelt Park
- **63** Training Sessions were held and consisted of
 - CPR Recertification
 - FF Rescue/Mayday
 - Ice Rescue
 - Patient Assessment
 - Victim Rescue
 - Pediatrics Assessment/Trauma
 - First Due Software
 - Utility Line Refresher
 - Environmental Emergencies
 - Human Trafficking
 - Elective/Shift Trainings
 - Make-up Trainings
- **1** Freedom of Information Act (FOIA) request was fulfilled
 - 2703 Henry Street

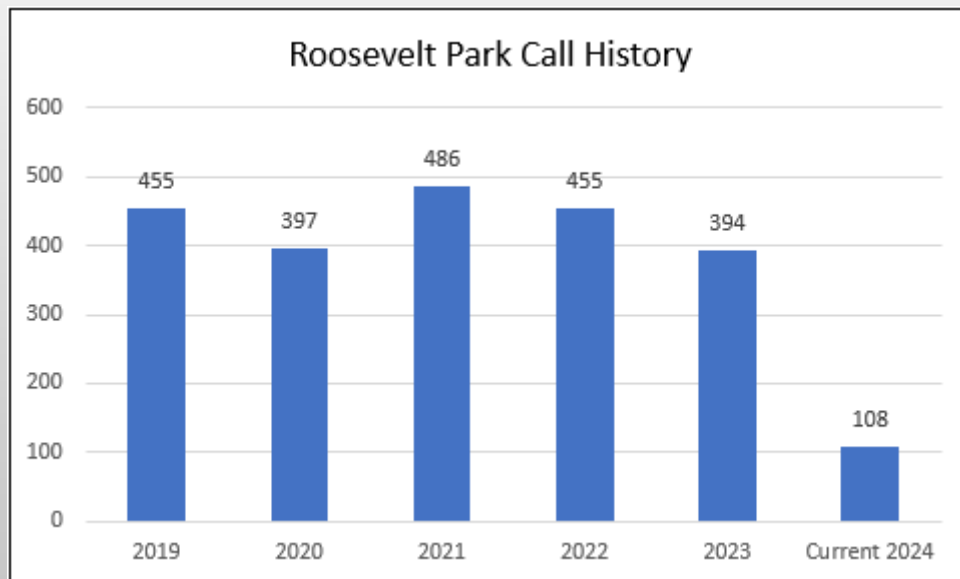



Administration

Dryer Fire

3/26/2024

3080 Maple Grove



CALLS BY INCIDENT TYPE - ROOSEVELT PARK

1/1/2024 - 3/31/2024

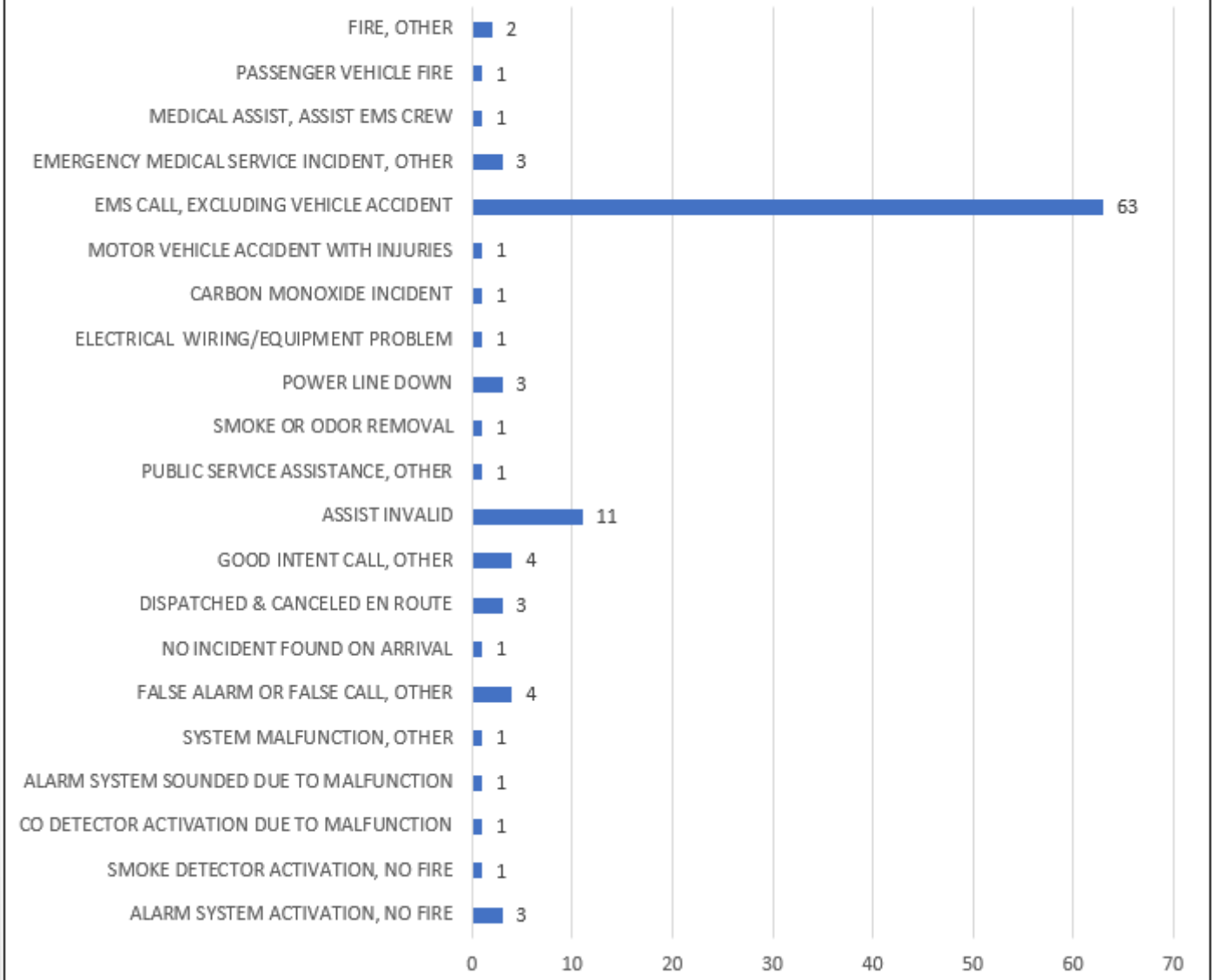

CALLS FOR SERVICE BY STATION ROOSEVELT PARK

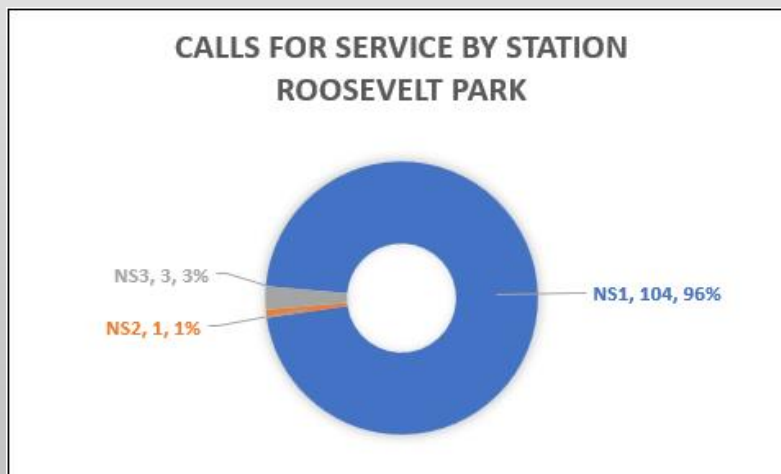



PERSONNEL TRAINING FOR THE QUARTER:

CPR Recertification	Department personnel recertify on the lifesaving skill of CPR every year.
Firefighter Rescue	There are unfortunate times when fire conditions change and place firefighters in a situation where they need to rescue themselves. By preparing through training and sharpening techniques, we can reduce the likelihood of an injury or death.
Opioid Crisis Review	Anthony Pantaleo, from MDHHS, presented the “Changing the Paradigm” program. Its purpose is to help understand how the opioid crisis affects all walks of life and how to care for the entire population who suffer from addiction.
First Due Software	All Muskegon County Fire Departments trained and prepared for the change to the new reporting software, First Due. The software provides the platform for reporting, asset management, inspection tracking, and personnel management modules.
Medical Training	Several medical emergency training topics were covered, including Airway/Ventilation/O2, human trafficking recognition, traumatic injury assessment, environmental emergencies, and pediatric emergencies.
Utility Line Identification	Representatives from Comcast/Xfinity provided a refresher training in identifying the types of utility lines we regularly encounter with line-down scenarios.
Hydrant Usage	Department personnel reviewed the proper operations of the different types of hydrants that we commonly use within our coverage area. This is important to avoid damage to our hydrants and keep them in good working order.



PERSONNEL TRAINING FOR THE QUARTER:

- 4-Gas Detector** Gas leaks of any nature can be dangerous. Knowing with certainty how to utilize our equipment effectively can save lives and avoid injury.
- CISM Training** Post Traumatic Stress is something that affects many who serve in public safety. CISM, or Critical Incident Stress Management, is a tool to help properly process these stresses. Personnel from Norton Shores Fire are in the process of training to be part of a County-wide team prepared to respond and help those in need.
- Dive Team** They utilized the Muskegon Heights High School pool to check equipment and practice essential diver rescue techniques and scenarios.
- New Hire Training** There were three new Part-Time Firefighters hired. They each received administrative training and have begun training at the Muskegon County Fire Academy, where they become certified firefighters.
- EMS Instructors Conference** The department Instructor/Coordinator licensed personnel attended the Spring Professional Development Conference in Traverse City to obtain the needed credits to maintain their licenses.
- Annual Fit Testing** This is a requirement for anyone expected to wear any kind of respirator, including N-95s for medical emergencies and Self-Contained Breathing Apparatus during fires. All personnel have completed the testing.
- Stop the Bleed** Department personnel team up with law enforcement to train nearly all Muskegon County law enforcement personnel in bleeding control techniques as part of their recent active assailant response training.



Fire Prevention Bureau

Fire Marshal Derek Hall

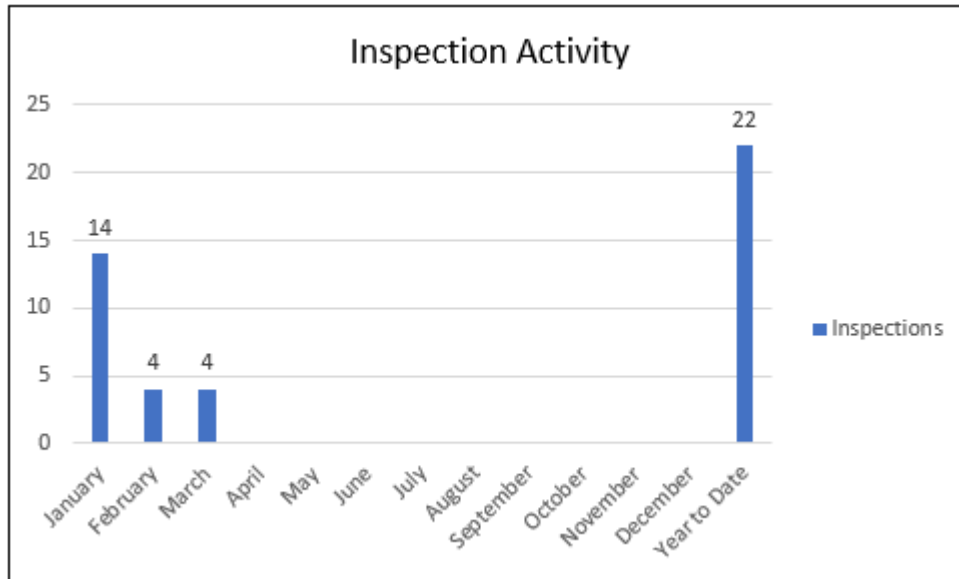

FIRE INSPECTIONS/SITE VISITS

January-March

- January (14) (6)
- February (4) (2)
- March (4) (2)

Fire Inspections	21
Site Visits	10
Licensure and Required	0
Re-inspections	12
Total Inspections	43
Lids only for Lock Boxes	2
Lock Boxes	0

SMOKE ALARM INSTALLS

January-March (0)

FOIA REQUESTS

January-March (0)

FIRE INVESTIGATIONS

Roosevelt Park
1

Muskegon County
0

PUBLIC EDUCATION EVENTS

January-March (0)



Social Media Monthly Data: Norton Shores Fire Dept.



@nortonshoresfd



@nortonshoresfire

NSFD Facebook	
Followers	8,555
Total People Reached	66,434
Total Reactions, Comments, and Shares	1,909

NSFD Instagram	
Followers	486
Profile Visits	79
Total People Reached	279

Norton Shores Fire Department
Published by Don VanderKooi · March 26 at 5:30 PM ·

PRESS RELEASE: Dryer Fire Incident at 3080 Maple Grove Rd.
This morning, shortly after 11 AM, the Norton Shores Fire Department responded to an emergency call reporting smoke in the hallway of the residential building at The Shores of Roosevelt Park.
Upon arrival, firefighters encountered a small fire within a dryer in the laundry area on the first floor... See more

Norton Shores Fire Department
Published by Don VanderKooi · January 29 ·

A full house today for Airway Management training this morning at Station #1
As part of the required training, and because breathing is essential to all of us to sustain life, this is a popular training.
#airwaymanagement... See more

Top Facebook Posts:	Reach	Likes and Reactions	Link Clicks	Comments	Shares
3/26/24: Dryer Fire Incident 3080 Maple Grove	3,996			18	9
1/29/24: Station #1 Airway Management Training	1,796			2	0