



CITY OF ROOSEVELT PARK CITY COUNCIL MEETING

AGENDA
May 18, 2026
6:15 p.m.

1. Council Work Session
2. Call to Order and Roll Call
3. Pledge of Allegiance
4. Invocation by Councilmember Benson
5. Public Comment on Agenda Items

6. Approval of Consent Agenda
 - a. Regular Agenda
 - b. Minutes of May 4, 2026- Regular City Council Meeting
 - c. List of Bills

7. Unfinished Business

8. New Business
 - a. Roosevelt Park Day Committee-Set Meeting Time and Date
 - b. Finance and Personnel Committee-Set Meeting Time and Date
 - c. Pedestrian trail/E-Bike Regulations-Council Discussion
 - d. Fiscal Year 2027-Set Public Hearing

9. Public Comment

Please state your name and home address
Please limit comments to 3 minutes per individual presentation
(City Council Rules of Procedure: 10/7/2011)

10. Comments from the Mayor and City Council
11. Reports from City Manager, City Attorney & Department Heads
12. Adjournment

American Disability Act Compliance: For access to open meetings of the City Council and any of its committees or subcommittees, the City of Roosevelt Park will provide necessary reasonable auxiliary aids and services, to individuals with disabilities who want to attend the meeting, upon twenty-four-hour notice to the City of Roosevelt Park. Individuals with disabilities requiring auxiliary aids or services should contact the City of Roosevelt Park, City Clerk by writing or calling, 231-755-3721 or call the following: TDD: Dial 7-1-1 and request a representative to dial 231-755-3721.



City of Roosevelt Park

A Proud Community

To: Honorable Mayor and City Council
From: Jared Olson, City Manager
Date: May 15, 2026
Subject: **Monday, May 18, 2026**– CITY COUNCIL MEETING

The following is information pertaining to items on the agenda for your meeting:
COUNCIL WORK SESSION:

1. Active Agenda Items

COUNCIL MEETING:

- a. **Roosevelt Park Day Committee-Set Meeting Time and Date-** The next date and time is needed for the 2026 Roosevelt Park Day Planning Committee.
- b. **Personnel and Finance Committee-Set Meeting Time and Date-** A meeting time and date needs to be set for an upcoming Personnel and Finance Committee. The primary focus of this meeting is to get additional feedback on proposed redevelopment projects for the vacant 1367 W. Sherman parcel.
- c. **Pedestrian trail/E-Bike Regulations-Council Discussion-** As we near completion of the nearly one-mile long section of trail way, staff is requesting further discussion on regulations governing e-bikes, electric scooters, and other motorized forms of transportation in relation to the trail way and sidewalks. Several local community trail way rules are included for examples along with the State of Michigan requirements.
- d. **Fiscal Year 2027-Set Public Hearing-** The formal public hearing for the upcoming Fiscal Year 2027 needs to be set to allow enough time for creation and publication requirements to be met. This is both a state and charter requirement.

If you have questions, please contact me.



**CITY OF ROOSEVELT PARK
CITY COUNCIL
MEETING MINUTES
May 4th, 2026**

This meeting was called to order by Mayor Aaron Langlois at 6:15 p.m.

PRESENT: Council Members: Mayor Aaron Langlois, Mayor Pro-Tem Michael Sutton, Diane Goodman, Donald Nilson, Noah Crossno, Derek Benson

STAFF: City Manager Jared Olson, City Treasurer Kate Dibble, City Clerk Alison Johnson, Police Chief Shawn Bride, City Attorney Brennan Gorman

ABSENT: Matt Johnson

UNFINISHED BUSINESS

- None

WORK SESSION

Council discussed Agenda Items:

- 2026/2027 Cornell Watermain Replacement- Engineering Proposal
- DDA Membership Resignation/Appointment
- Resolution of Appreciation- Council Adoption
- List of Bills

Special Guests:

- None

Mayor Langlois called the Council meeting to order at 6:26 p.m.

2026-081 **ROLL CALL**
Clerk Alison Johnson called the roll call.

2026-082 **INVOCATION**
Mayor Aaron Langlois provided the Invocation.

2026-083 **PUBLIC COMMENT ON AGENDA ITEMS**
none

2026-084 **CONSENT AGENDA**
Council Member Crossno, made a motion to approve the consent agenda as written. Council Member Goodman supported this motion.
Roll Call: 6 Ayes, 0 Nays, 1 Absent (Johnson). Motion Passes.

2026-085 **UNFINISHED BUSINESS**

None

2026-086 **NEW BUSINESS**

8A. 2026/2027 Cornell Watermain Replacement-Engineering Proposal

Council Member Benson moved to approval and engagement of Moore and Bruggink for the 2026/2027 Cornell watermain replacement project as presented. This motion was supported by Council Member Crossno.

Roll Call: 6 Ayes, 0 Nays, 1 Absent (Johnson). Motion Passes

8B. DDA Membership Resignation/Appointment

Council Member Goodman moved to accept the resignation with regret of Mike Nawrocki from the DDA and appoint Ann Wisniewski to the vacated position with a term expiring December of 2027. This motion was supported by Council Member Nilson.

Roll Call: 6 Ayes, 0 Nays, 1 Absent (Johnson). Motion Passes

8C. Resolution of Appreciation- DDA Member Mike Nawrocki

Council Member Crossno moved to adopt the resolution with appreciation and acknowledgment of the dedication of DDA Member Mike Nawrocki for his long-term commitment and volunteerism to the residents and community of the City of Roosevelt Park. This motion was supported by Council Member Nilson.

Roll Call: 6 Ayes, 0 Nays, 1 Absent (Johnson). Motion Passes

2026-087 **COUNCIL COMMENTS**

Council members shared comments.

2026-088 **DEPARTMENT HEAD REPORTS**

Department heads shared comments.

2026-089 **PUBLIC COMMENTS**

None

2026-090 **ADJOURNMENT**

Mayor Langlois moved to adjourn the meeting at 7:04 p.m. This motion was supported by Mayor Pro Tem Sutton and carried unanimously.

Alison Johnson, City Clerk



CITY OF ROOSEVELT PARK

A Proud Community
900 OAK RIDGE ROAD
ROOSEVELT PARK, MI 49441
(231) 755-3721

COUNCIL LIST

Friday, May 15, 2026

CHECK NUMBER	VENDOR NAME	DESCRIPTION	Invoice #	INVOICE AMT
6343 (E)	ACCIDENT FUND	WORKERS COMP MAY	1002365097	1,256.30
			Check Total	1,256.30
6344 (E)	ADVANCE AUTO PARTS	KUBOTA - JBWELD	538261322152	7.35
		PANEL RETAINER - KUBOTA	532613390639	7.61
			Check Total	14.96
6345 (E)	BANK OF AMERICA BUSINESS CARD	RESOLUTION FRAME	112812662527	39.99
		KEYBOARD RISER	111413086887	11.99
		RETIREMENT CAKE	042926	91.67
		MMTA CONFERENCE - HOTEL	39487	401.52
			Check Total	545.17
6346 (E)	BANK OF AMERICA BUSINESS CARD	RETIREMENT ICE CREAM/TABLE COVERS/WATER	042926	32.63
		COMMUNITY GARDEN PLANTERS	491653	304.22
		COMMUNITY GARDEN PLANTERS	0526	3,190.25
			Check Total	3,527.10
6347 (E)	BANK OF AMERICA BUSINESS CARD	WATER LICENSE CLASS - RYMAL	042826	164.02
			Check Total	164.02
6348 (E)	BLUE CARE NETWORK OF MI	RETIREE HEALTH CARE - JUNE	261290001629	2,718.94
			Check Total	2,718.94
6349 (E)	BLUE CROSS BLUE SHIELD OF MICH	RETIREE HEALTH CARE - JUNE	225861014	2,993.61
			Check Total	2,993.61
6350 (E)	CONSUMERS ENERGY	1000 0015 6057 936 OAKRIDGE GUL 2	203946245450	1,430.10
			Check Total	1,430.10
6351 (E)	CONSUMERS ENERGY	1000 0017 0686 3106 ROOSEVELT RD	203946245451	17.52
			Check Total	17.52
6352 (E)	CONSUMERS ENERGY	1000 0038 5011 TRAFFIC LIGHTS	203679313153	276.47
			Check Total	276.47
6353 (E)	CONSUMERS ENERGY	1030 2926 0835 49441 LED LIGHT RD	202166438237	2,058.55
			Check Total	2,058.55
6354 (E)	CONSUMERS ENERGY	1000 0015 1900 2848 ASHLAND	204569183001	70.58
			Check Total	70.58
6355 (E)	CONSUMERS ENERGY	1000 0015 2536 - 896 W BROADWAY	204569183011	60.73
			Check Total	60.73
6356 (E)	CONSUMERS ENERGY	1000 0460 5042 3105 ROOSEVELT	204035246829	74.37
			Check Total	74.37
6357 (E)	CONSUMERS ENERGY	1000 0460 5166 3106 ROOSEVELT	201543522030	81.97
			Check Total	81.97
6358 (E)	CONSUMERS ENERGY			



CITY OF ROOSEVELT PARK

A Proud Community
900 OAK RIDGE ROAD
ROOSEVELT PARK, MI 49441
(231) 755-3721

COUNCIL LIST

Friday, May 15, 2026

CHECK NUMBER	VENDOR NAME	DESCRIPTION	Invoice #	INVOICE AMT
		1000 0597 2995 1168 CORNELL	201721505852	32.49
			Check Total	32.49
6359 (E)	CONSUMERS ENERGY			
		1000 0616 4881 1580 GARRISON	202077486534	408.25
			Check Total	408.25
6360 (E)	CONSUMERS ENERGY			
		1000 0616 6274 3064 GLENSIDE	202077486535	30.11
			Check Total	30.11
6361 (E)	CONSUMERS ENERGY			
		1000 0622 0758 1344 GREENWICH RD	202255473330	29.94
			Check Total	29.94
6362 (E)	CONSUMERS ENERGY			
		1000 0678 0280 898 W BROADWAY	203501327324	89.75
			Check Total	89.75
6363 (E)	CONSUMERS ENERGY			
		1000 0777 1684 880 OAKRIDGE	202967362096	540.49
			Check Total	540.49
6364 (E)	CONSUMERS ENERGY			
		1000 0832 5373 3278 GERMAINE	202878373248	33.00
			Check Total	33.00
6365 (E)	CONSUMERS ENERGY			
		1000 0864 3968 1267 LAMBERT	202878373249	38.58
			Check Total	38.58
6366 (E)	CONSUMERS ENERGY			
		1000 0849 1167 3163 MAPLE GROVE	202878373250	50.91
			Check Total	50.91
6367 (E)	CONSUMERS ENERGY			
		1000 0864 2272 1140 SHERWOOD	202878373251	32.15
			Check Total	32.15
6368 (E)	FRONTIER			
		DPW GARAGE INTERNET	0526	44.99
			Check Total	44.99
6369 (E)	HEALTH EQUITY			
		MONTHLY FSA FEES	0526	75.00
			Check Total	75.00
6370 (E)	HOME DEPOT CREDIT SERVICES			
		PARKS/COMM CENTER/MAPLE GROVE PUMP	051326	271.12
			Check Total	271.12
6371 (E)	WEX BANK			
		GAS (DPW 300.927, PD 485.319)	112262617	2,630.09
			Check Total	2,630.09
6372 (A)	ACCURATE EXCAVATORS			
		REPLACEMENT OF HYDRANT - MAPLE GROVE/SUM	23924	1,713.00
		VAC TRUCK - 2 HRS	23941	600.00
			Check Total	2,313.00
6373 (A)	BORGMAN TREE SERVICE			
		TREE REMOVAL - BALLFIELD	4861	3,375.00
			Check Total	3,375.00
6374 (A)	CIVIC PLUS LLC			
		ONLINE CODE HOSTING	372037	529.20
			Check Total	529.20
6375 (A)	CORE & MAIN			



CITY OF ROOSEVELT PARK

A Proud Community
900 OAK RIDGE ROAD
ROOSEVELT PARK, MI 49441
(231) 755-3721

COUNCIL LIST

CHECK NUMBER	VENDOR NAME	DESCRIPTION	Invoice #	INVOICE AMT
		MARKING PAINT	Y962147	363.20
			Check Total	363.20
6376 (A)	DIBBLE, KATE	MMTA CONFERENCE TRAVEL	0526TRAVEL	205.90
			Check Total	205.90
6377 (A)	FISHER CONSULTING	HEARING OFFICER - 2967 HENRY STREET VICT	050126	3,878.00
			Check Total	3,878.00
6378 (A)	HAUBRICH, CHAD	WATER LICENSE	TRAVEL0526	57.28
			Check Total	57.28
6379 (A)	JARED OLSON	VISION REIMBURSEMENT	050526VISION	60.00
			Check Total	60.00
6380 (A)	JOHNSON, ALISON	VISION REIMBURSEMENT	VISION0526	86.40
		DENTAL REIMBURSEMENT	051426DENTAL	145.60
			Check Total	232.00
6381 (A)	KENT COMMUNICATIONS INC	POSTAL COURIER SERVICES	8876-172154	279.31
			Check Total	279.31
6382 (A)	MACQUEEN EQUIPMENT LLC	UNIT 4 - PLASTIC FITTING HOSE REPLACEMEN	23738	594.93
		MONTHLY LABOR - VEHICLE MAINTENANE JUNE	23755	926.10
			Check Total	1,521.03
6383 (A)	MBK CORPORATE PROMOTIONS	COUNCIL POLOS, DPW T-SHIRTS	69850	529.00
			Check Total	529.00
6384 (A)	MOORE & BRUGGINK, INC.	NON-MOTORIZED PATHWAY	250128.1-10	21,624.35
			Check Total	21,624.35
6385 (A)	MUSKEGON CENTRAL DISPATCH 911	IT SUPPORT	2600003349	465.93
		IMPRIVATA FEES - CITY HALL - MAY	2600003372	93.17
		IMPRIVATA FEES - PD - MAY	2600003396	80.32
			Check Total	639.42
6386 (A)	MUSKEGON CHARTER TOWNSHIP	CODE ENFORCEMENT - APRIL	2600017301	943.42
			Check Total	943.42
6387 (A)	PARMENTER LAW	GENERAL LEGAL/TAX APPEAL	299307	1,180.50
		PROSECUTIONS	299308	248.50
		VICTORY INN ENFORCEMENTS	299309	7,053.00
			Check Total	8,482.00
6388 (A)	PLANTENGA'S CLEANERS	UNIFORM CLEANING	0426	38.13
			Check Total	38.13
6389 (A)	PRO CLEAN SOLUTIONS	BUILDING CLEANING	ROO050126	300.00
			Check Total	300.00
6390 (A)	RADARSIGN	BATTERY CABLES/SPEED SIGNS	INV5073	169.00



CITY OF ROOSEVELT PARK

A Proud Community
 900 OAK RIDGE ROAD
 ROOSEVELT PARK, MI 49441
 (231) 755-3721

COUNCIL LIST

Friday, May 15, 2026

CHECK NUMBER	VENDOR NAME	DESCRIPTION	Invoice #	INVOICE AMT
			Check Total	169.00
6391 (A)	REPUBLIC SERVICES # 240	WASTE REMOVAL SERVICES - APRIL	0240-	28,927.75
			Check Total	28,927.75
6392 (A)	RYAN RYMAL	TRAVEL REIMBURSEMENT - WATER LICENSE, LO	TRAVEL0526	256.90
			Check Total	256.90
6393 (A)	WINDEMULLER	TRAFFIC LIGHT MAINTENANCE - APRIL	249954	384.20
			Check Total	384.20
6394 (A)	WOLF KUBOTA	KUBOTA ATV	301201	31,948.78
			Check Total	31,948.78
38720	ASHLEY IRRIGATION	IRRIGATION START UPS	3384	3,228.70
			Check Total	3,228.70
38721	AUTO VALUE MUSKEGON	LED MINI BAR	180-547977	90.89
			Check Total	90.89
38722	COLORADO GUN FIGHTER	SHIPPING FOR BALLISTIC HELMET	32126	88.49
			Check Total	88.49
38723	MORSE, MADISON	ALCOHOL COMPLIANCE DECOY	DECOY2026	100.00
			Check Total	100.00
38724	PAUL SCHULTZ TRUCKING AND EXCAVATION	TOP SOIL - BALLFIELD	7672	120.00
			Check Total	120.00
38725	SANBORN'S	FACADE GRANT REIMBURSEMENT	0526FACADE	2,000.00
			Check Total	2,000.00
38726	SEI BELLA	FACADE GRANT REIMBURSEMENT	0526FACADE	13,325.00
			Check Total	13,325.00
38727	SHORELINE SHUTTLE LLC	GOLF CART RENTAL	RPDAY2026	500.00
			Check Total	500.00
38728	SITEONE LANDSCAPE SUPPLY, LLC	GRASS SEED	165461899-	232.98
		FERTILIZER, GRASS SEED, MOUND CLAY	165790780-	330.69
		FERTILIZER RETURN	165793853-	(44.29)
			Check Total	519.38
38729	VALLIER FENCE COMPANY	BALLFIELD FENCE	BALLFIELD022	5,770.00
			Check Total	5,770.00
38730	WEST MICHIGAN SEPTIC SEWER & DRAIN	SENIOR MILLAGE SEWER CLEANING - 3098 COO	26300	340.00
			Check Total	340.00
38731	WILBUR PRODUCTS	FACADE GRANT REIMBURSEMENT	0526FACADE	13,542.50
			Check Total	13,542.50



CITY OF ROOSEVELT PARK

A Proud Community
900 OAK RIDGE ROAD
ROOSEVELT PARK, MI 49441
(231) 755-3721

COUNCIL LIST

Friday, May 15, 2026

CHECK NUMBER	VENDOR NAME	DESCRIPTION	Invoice #	INVOICE AMT
			Report Total	166,279.09



**CITY OF ROOSEVELT PARK
CITY COUNCIL MEETING
May 18, 2026**

Item: Set Roosevelt Park Day Meeting Time and Date	Date: May 18, 2026
<p>The next meeting needs to be set for our upcoming Roosevelt Park Day event. Planning so far is well underway, and staff is recommending it be scheduled for the week of June 8th.</p> <p>We continue to get strong responses for the parade, arts and crafts, and food vendors. The food vendors are now full with a total of twelve food trucks.</p>	
Financial Impact: None	
Recommendation: Set up a committee meeting for the 2026 Roosevelt Park Day event	
Signature:	Title: City Manager



**CITY OF ROOSEVELT PARK
CITY COUNCIL MEETING
May 18, 2026**

Item: Personnel and Finance Committee- Set Meeting	Date: May 18, 2026
<p>A meeting time and date needs to be set for an upcoming Personnel and Finance Committee. The primary focus of this meeting is to get initial feedback on proposed redevelopment projects for the vacant 1367 W. Sherman parcel.</p> <p>Staff is recommending the week of May 26th.</p>	
Financial Impact: None	
Recommendation: Set a time and date for the next Personnel and Finance Committee meeting.	
Signature:	Title: City Manager



CITY OF ROOSEVELT PARK CITY COUNCIL MEETING May 18, 2026

Item: Pedestrian Trail/ E-Bike Regulations-Discussion	Date: May 18, 2026
<p>As we near completion of the nearly one-mile long section of trail way, staff is requesting further discussion on regulations governing e-bikes, electric scooters, and other motorized forms of transportation in relation to the trail way and sidewalks. Several local community trail way rules are included for examples along with the State of Michigan requirements.</p> <p>The State of Michigan has categorized electric bikes into three separate categories as outlined below;</p> <ul style="list-style-type: none">• CLASS 1: Allowed on roads, bike lanes, and many paved non-motorized trails such as rail-trails. Some unpaved trails may allow Class 1 where specifically authorized.• CLASS 2 & 3: Allowed on roads and bike lanes. Access to paved trails and rail-trails depends on approval from the local authority. Always check local trail rules. One trail might allow Class 2, another might not.• OCEVs: Higher-powered electric vehicles that fall outside Michigan’s e-bike definition may require registration and street-legal equipment for road use. They are not treated the same as e-bikes. <p>As such, the three-category breakdown is now commonly referenced throughout numerous local ordinances and guidelines on allowed use areas per the type of bike. Attached to this memo is a breakdown of types and uses per the MiDNR along with the current rules and regulations from the City of Norton Shores and City of Muskegon.</p>	
Financial Impact: None	
Recommendation: Review and give direction to city staff in regard to possible draft ordinances and regulations for e-bike use and sidewalk/non-motorized trail use.	

We only use cookies that are necessary for this site to function to provide you with the best experience. The controller of this site may choose to place supplementary cookies to support additional functionality such as support analytics, and has an obligation to disclose these cookies. Learn more in our [Cookie Statement](#).

Subscribe to updates from Michigan Department of Natural Resources

Showcasing the DNR: Allowable e-bike operation expands under DNR change

Email Address:

Michigan Department of Natural Resources sent this bulletin at 08/08/2024 04:01 PM EDT

[Share or view as webpage](#) | [Update preferences](#)

Share Bulletin



Michigan Department of
Natural Resources
Caring for Michigan's outdoor places and stories since 1921



Showcasing the DNR



Allowable e-bike operation expands under DNR land use order change

Provisions of change in effect immediately after today's approval

By **HEATHER JOHNSON DUROCHER**

Trails and resources writer, Parks and Recreation Division
Michigan Department of Natural Resources

Allowable use of Class 1 electric bicycles on state-managed, nonmotorized bicycle trails/pathways has expanded following approval of a proposed Michigan Department of Natural Resources land use order.

DNR Director Scott Bowen approved the land use order change today during the Michigan Natural Resources Commission's monthly meeting, which was held at the Cadillac Place Building in Detroit.



"This decision opens our trails to be even more inclusive, providing opportunities to those unable to bike without assistance who want to continue riding and enjoying the outdoors," said Ron Olson, chief of the DNR's Parks and Recreation Division. "We anticipate all bikers and trail

users will continue to practice appropriate trail etiquette so all users can be safe and enjoy the expansive natural-surface trail system."

Definitions and details

An electric bicycle (or e-bike) is a bicycle that has a small rechargeable electric motor that can give a boost to the pedaling rider or can take over pedaling completely.

To qualify as an e-bike in Michigan, the bike must meet the following requirements:

- It must have a seat or saddle for the rider to sit.
- There must be fully operational pedals.
- It must have an electric motor of no more than 750 watts (or 1 horsepower).

Whether you can ride an e-bicycle on a trail depends on several factors, including the e-bike's class, the type of trail and whether the authority that manages or oversees the trail allows the use.

The [DNR land use order](#) approved today goes into effect immediately and expands operation of Class 1 e-bikes so that they are now allowed on improved-surface trails, such as linear trails (paved or gravel/asphalt) as well as natural-surface, nonmotorized bicycle trails/pathways in state parks and recreation areas and on state forest pathways and roads.

The prevailing concern about allowing electric bicycles on trails is the question of safety – particularly related to speed.

Class 1 e-bikes are pedal-assisted and can go up to 20 miles per hour



In addition, the change now allows operation of Class 2 e-bikes, which are throttle- and pedal-assisted and can travel up to 20 miles per hour, on those trails/pathways open for Class 1 e-bike use for mobility purposes as long as a cyclist had applied for and received a no-cost permit to do so.

Prior to the land use change, Class 1 e-bikes were only allowed on improved-surface trails and roads on state-managed land.

“Today’s director approval makes trail riding easier for people who may not have the physical ability to ride a traditional bike,” said Tim Novak, the DNR’s state trails coordinator. “This includes individuals living with disabilities, older adults and really anyone who wishes to experience some assistance as they ride a bicycle. Class 1 e-bikes require pedaling, providing a great health benefit to riders.”

The DNR is installing signs at trailheads indicating allowable e-bike use.

E-bikes remain prohibited in state game and wildlife areas, on Congressionally authorized trails such as the North Country National Scenic Trail or on these three pathways in the Pigeon River Country in the northern Lower Peninsula: High Country, Shingle Mill and Pickerel Lake.

Class 3 e-bikes, which are pedal-assisted and have a maximum speed of 28 miles per hour, remain prohibited on any state-managed nonmotorized trail.



Current law allows for local entities to expand or further regulate e-bike usage in their respective communities.

Informed decision-making process

The land use change comes after many months of research as well as conversation and

collaboration among DNR staff and trail user groups, including the League of Michigan Bicyclists and the Michigan Mountain Bike Alliance.

The DNR also gathered feedback on the then-proposed change through a public survey that was open earlier this year.

The League of Michigan Bicyclists and Michigan Mountain Bike Alliance support the land use order change, according to Matt Penniman, who serves as the organizations' communications and advocacy director.

"Theodore Roosevelt once wrote, 'I believe in power, but I believe that responsibility should go with power.' We believe in the power of e-bikes to help more people access Michigan's incredible mountain bike trails," Penniman said. "We also believe in the responsibility of riders to follow the rules, practice good trail etiquette and treat our trails with respect.

"Over the past year and a half, the DNR has engaged well with the mountain bike community on this change. We expect a continued responsible approach from the DNR to increase resources for education, enforcement and trail maintenance, in parallel with increased use."

Nicole Hunt, regulatory unit manager with the DNR, said e-bike use is indeed continuing to grow across the country, with many states approving areas for their use.

"The DNR's decision to move forward with this land use change wasn't based on a desire to be trendy, but rather on providing individuals with more recreation options while also being conscientious of our state's natural and cultural resources," Hunt said.

Considering federal government recognition of e-bike use also was part of the process.

"The federal government, recognizing the benefit of e-bikes for trail recreation, updated its federal grant funding regulations for

nonmotorized, natural-surface trail development to no longer prohibit use of e-bikes on trails developed with federal funds," Hunt said.

Novak said the DNR also researched how other states are allowing e-bike usage.

"We have benchmarked other states and local trail systems that allow e-bikes on natural-surface, nonmotorized trails, and what we found was there haven't been issues with conflicts or injuries or unnecessary wear and tear on our natural resources which would cause any reservation in expanding e-bike use," Novak said.

Hunt said the Arkansas state park system stood out, as it has a vast number of trails, including mountain biking trails, and has allowed e-bikes for years with no issues.

The DNR plans to monitor e-bike usage in the coming months. This will include sharing a new public survey as well as speaking with riders on the trails and with trail user groups during to-be-scheduled virtual public meetings.

More details on these events will be shared soon.

Learn more about e-biking in Michigan, the current e-bike policy on state-managed park land and upcoming e-bike public meetings at Michigan.gov/DNR/Ebikes.

Check out previous Showcasing the DNR stories in our archive at Michigan.gov/DNRStories. To subscribe to upcoming Showcasing articles, sign up for free email delivery at Michigan.gov/DNREmail.



Note to editors: Contact: [John Pepin](#), Showcasing the DNR series editor, 906-226-1352. Accompanying photos and a text-only version of this story are available below for download. Caption information follows. Credit Michigan Department of Natural Resources, unless otherwise noted.

[Text-only version of this story.](#)

Charging: An open charging compartment is shown on an e-bike. It takes about 3.5 hours to fully charge and e-bike with a dead battery.

Class-1: A Class-1 e-bike is shown. These bikes can travel up to 20 miles per hour.

Class-3: A Class-3 e-bike is shown. These bikes have a maximum speed of 28 miles per hour.

Label: A label on an e-bike shows which type it is, how many watts and maximum speed. Such labels are required for e-bikes.

Motor: A motor compartment is shown on a Class-1 e-bike.

Shop: Jacob Douglas, co-owner of Lakeshore Bike in Marquette, moves an e-bike back into a selection of e-bikes at his shop.

The Michigan Department of Natural Resources is committed to the conservation, protection, management, use and enjoyment of the state's natural and cultural resources for current and future generations. For more information, go to Michigan.gov/DNR.



If you wish to no longer receive emails from the DNR, please update your preferences here:
[Manage Preferences](#) | [Unsubscribe All](#) | [Help](#)

Need further assistance?
[Contact Us](#) | [Provide Feedback](#)

Visit us on our website: Michigan.gov/DNR

Get personalized voter information on early voting and other topics at Michigan.gov/Vote.

Powered by



[Privacy Policy](#) | [Cookie Statement](#) | [Help](#)



E-Moto vs. E-Bike - Michigan

Understanding the Problem and Crafting Effective Solutions

Electric bicycles (e-bikes) are a widely adopted, legally defined form of transportation that provide affordable, low-speed mobility for people of all ages and abilities. Increasingly, consumers are, often unknowingly, purchasing high-powered electric motorcycles or mopeds that are incorrectly marketed or assumed to be e-bikes. These vehicles are commonly referred to as “e-motos.”

When serious crashes occur, e-motos are frequently mischaracterized as e-bikes, creating confusion for policymakers and the public while undermining legitimate e-bike use.

E-Bike



“Pedal-assist electric bicycle (≤750W)”
1. Traditional bicycle frame
2. Visible pedals and chain
3. Compact motor and battery

E-bikes are legally defined in Michigan (MCL 257.13e) and almost every state using a three-class system and must meet federal safety standards. Across all classes, an electric bicycle must have:

- Operable pedals + seat or saddle
- An electric motor of 750 watts or less
- Motor-assisted speed limited to: 20 mph (Class 1 + 2) or 28 mph (Class 3)
- E-bikes are designed to function as bicycles, rather than motor vehicles, and are regulated accordingly.

- A **class 1** e-bike can be motor-assisted up to 20 miles per hour when pedaling.
- A **class 2** e-bike can also have a throttle to engage the motor without pedaling.
- A **class 3** e-bike can be motor-assisted up to 28 miles per hour when pedaling.

E-Moto



“High-powered electric motorcycle (motor vehicle)”
1. Motorcycle-style frame
2. Bench seat and wide tires
3. Large battery and motor housing

E-moto is a general term for electric mopeds, motorcycles, and dirt bikes that do not meet the legal definition of an e-bike. E-motos are motor vehicles but are often conflated with e-bikes despite having vastly different performance and risks.

Common e-moto characteristics include:

- Motors ranging from 1,000 to 6,000+ watts
- Top speeds of 30 to 65 mph
- Fake or non-functional pedals, or no pedals
- Weights often exceeding 100 pounds
- Bench-style seats, “moto-style” open frames, and large battery systems

E-Moto Risks

Many buyers reasonably assume that any product marketed as an “e-bike” is low-speed and appropriate for youth. Misleading marketing and inconsistent regulation allow high-powered electric motorcycles to be sold as e-bikes both in stores and online, often without clear warnings that they are motor vehicles. Parents may unknowingly purchase an unregistered motor vehicle for their child.

Safety and Legal Risks

- Underage riders often lack road experience and knowledge of traffic laws.
- High speeds and vehicle weight significantly increase crash likelihood and severity.
- E-motos are frequently illegally operated in bike lanes, trails, or sidewalks where motor vehicles do not belong.
- Operators may be cited for operating an unregistered motor vehicle.
- Operators must have a driver's license and possibly a motorcycle license.
- Violations may affect driving records and future insurance costs.
- Legitimate bike retailers may face liability exposure or reputational harm due to consumer confusion.
- E-moto crashes and citations are increasing, while unclear definitions complicate consumer awareness, law enforcement, and policymaking.

Addressing E-Motos

Michigan e-bike law was designed for low-speed bicycles that coexist safely with pedestrians. Allowing high-speed e-motos to masquerade as e-bikes undermines public trust and endangers access that legal e-bike cyclists enjoy. Despite the growing problem of these unregulated and under-defined vehicles, there are solutions available to lawmakers:

Better define these vehicles in state vehicle code.

- Update vehicle codes to exclude any vehicle capable of exceeding 20 mph under motor power alone from the definition of “electric bicycle.”

Create new regulatory standards for e-motos.

- Ban vehicles and devices designed to easily bypass e-bike speed or power limits.
- Prohibit false or misleading claims about what is “street legal.”
- Require disclosure of true vehicle type in all advertising.

Regulate the sellers of e-motos.

- Enforce existing and new laws against manufacturers and retailers selling deceptive or illegal e-motos.
- Require compliance with motor vehicle and dealer licensing regulations.

Educate the public and enforce new and existing laws.

Provide education for consumers, parents, schools, law enforcement, and government officials on the differences between e-bikes and e-motos.

E-bikes are a proven, low-speed transportation solution that expand mobility and access. E-motos are fundamentally different vehicles that require appropriate regulation. Clear definitions, strong enforcement, and public education will protect riders, communities, and the integrity of e-bike policy without limiting access to safe, affordable transportation.

Andy Rohrer | Executive Director | execdir@lmb.org
Neal Glazebrook | Events Director | neal@lmb.org

Information provided by People For Bikes

MUSKEGON CITY CODE

ARTICLE VI. ELECTRIC SCOOTERS AND BIKES

Sec. 92-100. Purpose.

The purpose of this article is to promote the health, safety and welfare of persons operating electric scooters and electric bikes within the city, and to protect the safety of other users of roads and bike trails.

(Ord. No. 2415, § 1, 6-25-2019)

Sec. 92-101. Definitions.

For the purposes of this article, the following words and phrases shall have the following meanings:

Bike path means the sections of the Muskegon Lakeshore Trail, which follows the shore of Muskegon Lake and parallels Lakeshore Drive and Shoreline Drive, that lie within the city.

Direct visual supervision means direct visual observation, by an adult who is in control of the operator, with the unaided or normally corrected eye, where the observer is able to come to the immediate aid of the operator.

Electric bike means a bicycle with an integrated electric motor which can be used for propulsion. Electric bike does not include a vespa or moped-like vehicles, motorcycles, dirt bikes, ORVs, gas scooters, or any similar vehicle.

Electric scooter means a light two-wheeled electric vehicle on which the driver stands on the floorboard or deck. Electric scooter does not include a vespa or moped-like vehicles, motorcycles, dirt bikes, ORVs, gas scooters, or any similar vehicle.

Operator means only persons over 14 years of age or those under 14 years of age but over 12 years of age and under direct visual supervision of an adult who is in control of the operator. (Ord. No. 2415, § 2, 6-25-2019)

Sec. 92-102. Rules and regulations.

This article is to establish guidance in the interest of public safety.

- (1) Electric scooters and electric bikes may be operated on local roads, public parks, and the bike path.
- (2) Electric shooters and electric bikes shall not be operated on or alongside any sidewalk. Electric scooters are prohibited on all state trunk roads.
- (3) Only persons over 14 years of age or those under 14 years of age but over 12 years of age and under direct visual supervision may operate an electric scooter or electric bike.
- (4) Any person who operates an electric scooter or electric bike on a public road must adhere to all applicable state and local laws, regulations and ordinances, including, but not limited to, those banning the possession and use of alcoholic beverages, and all other illegal drugs. In addition, no electric scooter or electric

bike containing any open container of alcohol shall be operated on public roads.

- (5) The operator of an electric scooter or electric bike shall comply with all traffic rules and regulations adopted by the State of Michigan and the city which governs the operation of motor vehicles.
- (6) An operator may not allow the number of people in or on an electric scooter or electric bike at any one time to exceed the maximum capacity specified by the manufacturer. The operator shall not allow passengers to ride on any part of an electric scooter or electric bike not designed to carry passengers.
- (7) In no instances shall an electric scooter be operated at a speed greater than ten miles per hour on the bike path.
- (8) No electric scooter or electric bike may be operated at a speed greater than reasonable and prudent for the existing conditions.
- (9) Electric scooters and electric bikes must be operated at the right edge of the roadway and must yield to all vehicular and pedestrian traffic.
- (10) Electric scooters and electric bikes are prohibited from parking on any sidewalk or any other location that impedes vehicular or foot traffic. All other parking rules and limits apply.
- (11) Electric scooters and electric bikes must have basic equipment supplied by the manufacturer.

(Ord. No. 2415, § 3, 6-25-2019)

Sec. 92-103. Registration.

All electric scooters and electric bikes are subject to city registration requirements imposed upon bicycles.

(Ord. No. 2415, § 4, 6-25-2019)

Sec. 92-104. Enforcement.

Violation of the provisions of this article shall constitute a civil infraction and carry a penalty of not less than a \$100.00 fine for a first viola-

tion, not less than a \$250.00 fine for a first repeated violation, and not less than a \$500.00 fine for a second repeated offense or any subsequent repeat offense.
(Ord. No. 2415, § 5, 6-25-2019)



CITY OF NORTON SHORES
SIDEWALKS, RECREATIONAL TRAILS AND PATHS
RULES AND REGULATIONS

DEFINITIONS

The following words and terms are defined for the purpose of their use in this Resolution. Any word or term not defined in this Resolution shall be considered to be defined in accordance with its common or standard definition.

1. **Bicycle:** A device propelled exclusively by human power upon which a person may ride, having either two (2) or three (3) wheels in a tandem, or tricycle arrangement.
2. **Motor Vehicle:** A vehicle which is self-propelled by gas or electric motor (except electric scooter).
3. **Person:** Shall mean any person, or any firm, corporation (profit or nonprofit), or any association (incorporated or unincorporated).
4. **Sidewalk, Recreational Trail or Path:** That portion of a street right-of-way and adjacent easements which is constructed and paved separate and apart from the paved street surface and which is for the use of pedestrians, bicycles and other uses specifically authorized herein.
5. **Sign:** A lettered board, banner or other display placed on or near a Recreational Trail or Path by or at the direction of the City for the purposes of transmitting a command, warning, direction or other message to persons utilizing a Recreational Trail or Path or who may be crossing a Recreational Trail or Path.

PROHIBITION

No person shall operate or ride an automobile, truck, tractor, E-Bikes, moped, snowmobile, motorcycle, ATV, golf cart, or any other type of motor vehicle upon any Sidewalk, Recreational Trail or Path within the City except to enter or leave adjacent property. This Section shall not be construed to prohibit the use on any recreational trail or path by persons using motorized wheelchairs or Class 1 E-Bike. Horseback riding is not allowed.

BICYCLE OPERATION

No person shall operate a bicycle or scooter on a Sidewalk, Recreational Trail or Path at a speed greater than is reasonable and prudent under the conditions then existing. Each person operating a bicycle or scooter on a Sidewalk, Recreational Trail or Path shall exercise due care at all times. Any person operating a bicycle or scooter on a Sidewalk, Recreational Trail or Path shall yield the right-of-way to Motor Vehicles that are crossing the Sidewalk, Recreational Trail or Path. This section shall not apply to any use on a designated bicycle lane or paved shoulder of a roadway.

DAMAGE

No person shall willfully or maliciously, or wantonly and without cause, destroy, injure, mutilate, deface, paint on, write on, alter, remove or otherwise damage or carry away a Recreational Trail or Path, or any sign relating thereto.

PARKING AND DEBRIS

No person shall stop, stand or park, or cause to be stopped, standing or parked, any vehicle, trailer, mobile home, motor home, camper or boat upon a Sidewalk, Recreational Trail or Path so as to obstruct the free passage of others. No person shall deposit or burn, or cause to be deposited or burned, any leaves, branches, grass, brush or other yard debris upon a Sidewalk, Recreational Trail or Path, or deposit, or cause to be deposited, any earth, stone, sand, gravel, trash, rubbish, cans, bottles, broken glass, nails garbage cans or any other dangerous objects or debris upon a Sidewalk, Recreational Trail or Path.

ANIMALS

Any person who owns or exercises any dominion or control over any animal shall, in the event that such animal deposits any fecal matter on any Sidewalk, Recreational Trail or Path, immediately and completely remove such matter. This section shall not be interpreted to prohibit the presence of animals on Sidewalk, Recreational Trail or Paths, except as otherwise prohibited herein.

DEPOSIT OF ICE OR SNOW

No person, in removing snow, ice, or slush from private property, or from public property under his or her control such as a driveway or approach, shall dump or deposit, or cause to be dumped or deposited such snow, ice, or slush, either temporarily or permanently, on any Sidewalk, Recreational Trail or Path within the City without the express written permission of an authorized City officer or employee.

VEGETATION

No person shall plant any trees, shrubs, or other vegetation in a location that obscures the view at intersections of a Recreational Trail or Path with a street or road or with another Recreational Trail or Path, and no person shall allow trees, shrubs, or other vegetation to grow to a size that obscures the view or obstructs passage along a Sidewalk, Recreational Trail or Path.

IRRIGATION

No person shall leave any garden hose, lawn sprinkler or other irrigation device or implement unattended when such hose, sprinkler, device or implement is in contact with or runs across or over the panel surface of a Sidewalk, Recreational Trail or Path.

CONSTRUCTION PROJECTS

If any construction project on lands adjoining a Sidewalk, Recreational Trail or Path results in damage to a Sidewalk, Recreational Trail or Path, then all such damage to the above shall be fully restored to its former condition within ten (10) days after the construction project is complete, provided, however, that if weather conditions prohibit full restoration of the Sidewalk, Recreational Trail or Path to its former condition within such ten (10) day period, then the Sidewalk, Recreational Trail or Path shall be

temporarily patched and restored so as to permit reasonable utilization by bicycles and pedestrians within such ten (10) day period and full repair and restoration to its former condition shall then be completed as soon as weather permits. In addition, an occupancy permit shall not be granted under any City Zoning Resolution or Building Code for any building or structure unless and until the Sidewalk, Recreational Trail or Path damaged in the construction of such building or structure has been fully repaired and restored to its former condition, provided, however, that if weather conditions then prohibit full repair and restoration of the Recreational Trail or Path to its former condition, an occupancy permit may be granted if (i) the Recreational Trail or Path has been temporarily patched and restored so as to permit reasonable utilization by bicycles and pedestrians and (ii) the City is provided with adequate financial security in the form of a cash deposit, letter of credit, or bond, to guarantee full repair or restoration of the Sidewalk, Recreational Trail or Path to its former condition as soon as weather permits.

BANNERS

No person shall suspend any sign, banner, printed leaflet, or other similar object above a Recreational Trail or Path, nor shall any person tape or affix any sign, banner, printed leaflet or other similar object to a Recreational Trail or Path without the express written permission of an authorized City officer or employee.

NONDESIGNATION

Public Sidewalks, Recreational Trails and Paths are provided for the benefit and enjoyment of pedestrians, persons in wheel chairs and bicyclists. The approval and adoption of this Resolution by the City Council shall not be deemed to be a designation of any Recreational Trail or Path as a bicycle path. The City Council expressly reserves the right to designate any Recreational Trail or Path as a bicycle path. Any such designation shall be made exclusively by a resolution of the City Council. Any resolution making such a designation shall expressly state that it is a designation of a Recreational Trail or Path shall refer to the Michigan Vehicle Code, MCL 257.660c, or any successor section thereto.

VIOLATIONS

Any person, firm, or corporation which violates the provisions of this Resolution shall be responsible for a municipal civil infraction. The sanction for a violation of this Resolution shall be a civil fine of not less than \$50.00, plus costs and other sanctions. Increased civil fines may be imposed for repeated violations of this Resolution by a person, firm, or corporation. A "repeat violation" of this Resolution is a second or subsequent violation of this Resolution committed by a person, firm, or corporation within six (6) months of a prior violation of this Resolution, and for which the person, firm, or corporation admits responsibility or is determined to be responsible. The sanction for a violation of this Resolution which is a first repeat violation shall be a civil fine of not less than \$250.00, plus costs and other sanctions. The sanction for a violation of this Resolution which is a second or subsequent repeat violation shall be a civil fine of not less than \$500.00, plus costs and other sanctions. The Mayor, City Administrator, any authorized City officials, the City Director of Public Works, the Streets and Drainage Superintendent and the City Attorney are authorized to issue municipal civil infraction citations for violations of this Resolution.

SEVERABILITY AND CAPTIONS

This Resolution and the various parts, sections, subsections, sentences, phrases and clauses thereof are hereby declared to be severable. If any part, section, subsection, sentence, phrase or clause is adjudged unconstitutional or invalid, it is hereby declared that the remainder of this Resolution shall not be affected thereby. The captions included at the beginning of each section are for convenience only and shall not be considered as a part of this Resolution.

ADMINISTRATIVE LIABILITY

No officer, agent, or employee of the City shall render himself or herself personally liable for any damage, consequence, or occurrence that may occur to any person as a result of any act performed in the discharge of his or her duties pursuant to this Resolution.

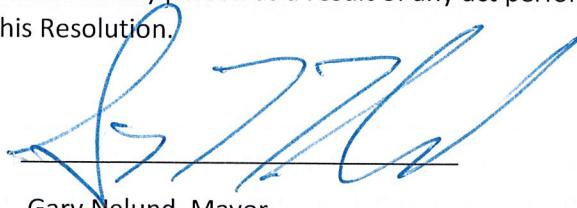

Gary Nelund, Mayor

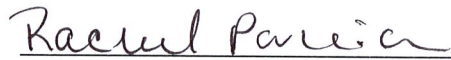

Rachel Pavlich, City Clerk



**CITY OF ROOSEVELT PARK
CITY COUNCIL MEETING
May 18, 2026**

Item: Set Public Hearing for FY 2027 Budget		Date: May 18, 2026
<p>Summary: As required by charter and law, a public hearing on the proposed millage rate and the City’s budget for the upcoming fiscal year is needed. This year, the City Council is scheduled to review the budget and take public comments at the September 8th meeting.</p> <p>The action being taken at this time is for the scheduling of the public hearing only for the millage rate and the upcoming budget. A public notice announcing the hearing will be published in a newspaper of general circulation. Per the City of Roosevelt Park requirements, the FY 2027 budget will have to be approved no later than the September 21st meeting.</p>		
Financial Impact: None.		
Recommendation: To set the public hearing on property taxes and the proposed Fiscal Year 2027 budget for Tuesday, September 8, 2026 at 6:15 p.m.		
Signature:		Title: City Manager

City of Roosevelt Park

A Proud Community

Informational Updates

The following documents are informational updates and documents relating to our community. They are for your information only and no action is requested.

**Muskegon Area Sports Hall
of Fame**
470 W. Western Ave.
Muskegon, MI 49440



Contact:
Tim Lipan
231-740-0982
Lipant@comcast.net

News Release

For Immediate Release

Celebrating Muskegon's Athletic Excellence

“Upcoming Induction Ceremonies Honor Local Sports Legends & Student Athletes of the Year”

MUSKEGON, Mich., May 14, 2026 – The 39th Annual Muskegon Area Sports Hall of Fame Induction Ceremony & Fundraiser is an opportunity to honor our local sports heroes and legends.

This year the Hall of Fame will welcome a State Championship Little League Team, a coaching legend, a star high school and college basketball player, an iconic wrestling family, a beloved teacher, coach and official, two student athletes and a legendary female baseball player.

The event will be held at the Event Center at Fricano Place, 1050 W Western Ave., Muskegon, MI 49441 on Saturday June 6, 2026. Social Hour at 5:00pm, dinner at 6:00pm with the program beginning around 6:45pm.

The 2026 Muskegon Area Sports Hall of Fame has a first this year. The local Hall of Fame has inducted a team 14 times in its 39-year history, but all of those were high school, college or professional teams. This year, the Hall of Fame will induct its first Little League team. But this isn't just any old Little League team...

The **2001 Roosevelt Park Little League Team** is the only team in area history to win a coveted Little League state championship - beating perennial powers like Taylor, Georgetown and Grosse Pointe along the way and then advancing to the regional tournament in Indianapolis and coming within one game of an appearance at the Little League World Series in Williamsport, Pa. “The Park Boys,” who are celebrating the 25th anniversary of their state championship run, headline the 2026 Class.

The rest of the 2026 Muskegon Area Sports Hall of Fame induction class is comprised of one of the Muskegon area's great high school football coaches, leading teams for 40 years – **Dave Cooke**; a high school and college basketball star – **Drew Naymick**; and an entire championship wrestling family - **The Zeerip Family**.

The Gene Young Distinguished Service Award recipient is **Frank Schubert** a beloved teacher and coach, who was also well known throughout the Muskegon area as an official.

The 2024 Scholar Athlete Award recipients are **Mariah Sain**, Muskegon High School (Basketball, Track, Volleyball) and **Marvin Moore**, Reeths-Puffer High School (Basketball, Track, Football).

And for the first time ever, the Sports Hall of Fame Legacy Award is honoring the greatest female baseball player in Muskegon history, **Doris Sams**.

“The Muskegon Area Sports Hall of Fame continues its storied tradition of excellence by welcoming another stellar class of sports legends,” said Hall of Fame President, Dan Beckeman. “This ensures that the grit, talent, and triumphs of our local icons are etched permanently into our area’s history.”

There will be a buffet style dinner catered by Harris Catering. The menu includes house salad, beef brisket, braised green beans, and roasted garlic mashed potatoes. Adult beverages will be available for purchase.

Tickets are \$50 each. To purchase tickets, visit www.Eventbrite.com and search Muskegon Area Sports Hall of Fame. For more ticket information, please write Terri Clock at tclock@mpsk12.net. Follow us on Facebook at: <https://www.facebook.com/share/1An2unBL3p/>

More details on our honorees are listed below:

Class of 2026

Student Athlete of the Year Award Recipients

Mariah Sain

This standout athlete for Muskegon High School earned letters in basketball, track and volleyball during her high school career. She led her basketball team to a State Championship in 2026 and was runner up for the 2026 Michigan Miss Basketball Award. Mariah garnered many awards in her senior year of basketball including 1st Team All-State, Muskegon Area MLive Player of the Year and the Detroit Free Press 2026 Dream Team. She made the honor role all four years of high school and is a member of the National Honor Society and has a GPA of 4.02.

Her volunteer work includes activity as a Peer Mediator for 3 years, a volunteer at the Charles Hackley Middle School and Bunker and Marquette elementaries, a member of the Lakeshore Youth Leadership Council and the Youth Advisory Council for the Muskegon Community Foundation. She plans to attend the University of North Carolina at Charlotte on a basketball scholarship and will pursue a career that will allow her to give back to the youth of the community.

Marvin Moore

This outstanding athlete earned letters in basketball, track and football during his high School career at Reeths-Puffer High School. His leadership skills were present as team captain in basketball, football and track. His accolades include three time All Conference in basketball, MLive Basketball Dream Team, two time All Conference in Track and 2026 Academic All-State.

Our recipient is also a member of the National Honor Society carrying a 3.977 GPA. His volunteer work includes being a PAL Mentor (Peer Assistant Leadership - mentoring K- 8th grade students). Marvin founded Rocket-Powered.org, a non-profit youth empowerment organization committed to igniting young people's confidence, fueling their potential and launching them toward brighter futures.

His future plans are to attend Kalamazoo College where he will continue to play basketball and major in accounting and pursue a career in forensic accounting.

2001 Roosevelt Park Little League Baseball Team

The 2001 Roosevelt Park Little League Team is the only team in area history to win a state championship in the traditional little league 11 and 12-year-old division since the tournament began in 1957.

In fact, the only other Little League team from the Muskegon area that has won a state championship in any age division was this same group of boys that won the 9 and 10-year-old title in 1999.

Roosevelt Park rolled over its four District opponents in 2001 by a combined score of 66-4, then scored wins over St. Claire, Taylor, Midland, Georgetown and Grosse Pointe to win the state championship in the small, Upper Peninsula city of Norway.

"The Park" then kept things going at the Little League Regional Tournament in Indianapolis, before falling in the championship game with a spot in Williamsport on the line, which was televised on ESPN2.

Team members were Chris Mattson, Andrew Carlson, David Mowers, Matt Ulfsax, Jacob Polanyi, Josh Sharpe, Scott Schuitema, Justin Judd, Jordan Bundt, Matt Callow, Troy Forton and Kyle Mattson. The team was coached by Steve Schuitema, who was

assisted by Craig Bundt, Dale Carlson and Randy Forton.

The Zeerip Family

The last name Zeerip is synonymous with wrestling success, coming out of the small town of Hesperia and rising all the way to the mats at the University of Michigan and then coaching the sport.

It all started with dad, Craig Zeerip, a standout wrestler at Ohio State who became the head coach at Hesperia and later Fremont.

Craig Zeerip became Hesperia's assistant coach when his three sons - Justin, Brandon and Collin - went through the program.

Justin finished his prep career with a perfect 260-0 record and four state titles and set a national record for career pins with **203**, before going on to win 100 matches at U-M.

Brandon was 251-7 with two state titles, wrestling at Michigan and later Eastern Michigan. He also starred at football, setting Hesperia's single season rushing record at 1375 yards.

Collin finished 238-13 at Hesperia with three state championships at three different weight classes, also wrestling at U-M and Eastern.

Justin and Collin have followed in their father's footsteps and are now co-head wrestling coaches at Whitehall.

Their family is held up as an example of combining athletic excellence, academic achievement (all were valedictorians), and community roots in a small town.

Dave Cooke

Dave Cooke is recognized as one of the Muskegon area's great high school football coaches, leading teams for 40 years at Whitehall, Reeths-Puffer and the final 22 years at North Muskegon.

Cooke was a football, basketball and track star at Muskegon High School, who went on to be a starting halfback at Western Michigan.

After one year as an assistant coach at Whitehall, he became the Vikings' head coach at age 23, when he guided his team to a 7-1 record and co-champions of the Seaway Conference. He then went to Reeth-Puffer High School, where he won conference titles in 1973 and 1977.

Cooke, who finished with a head coaching record of 183-124-1, is perhaps best known for his tenure at North Muskegon, where he guided the Norsemen to the playoffs in 13

of his 22 years, highlighted by a state runner-up finish in 1981.

Drew Naymick

Drew Naymick was a dominant, 6-10 center for North Muskegon. In high school he was notable as a shot-blocker: for example, at one point he owned the Michigan high school record for career blocks with at 527.

Naymick was named to the Detroit Free Press Dream Team and earned a spot on The Detroit News Class C All-State Team averaging 18 points, 10.7 rebounds and 5.5 blocks as a senior at North Muskegon. He led his team to a 24-2 record and a berth in the Class C state quarterfinals. Naymick, proved he had the all-around game to be a key part of Michigan State's basketball success in the early 2000s.

Naymick became a starter at MSU in his junior and senior seasons, and was known for his defense and rebounding. At one point he held the Spartans' career record with 134 blocked shots.

Naymick parlayed his size, smarts and diverse skill set into a long professional career overseas, which started in Poland and included stops all over Europe, Latin America, Greece, Japan and Australia - winning numerous championships along the way.

Gene Young Distinguished Service Award

Frank Schubert, 93 years old, is a beloved figure in the Reeths-Puffer community as a longtime teacher and coach, who was well known throughout the Muskegon area as an official.

Schubert is a Manistee native who played quarterback and running back at Ferris State, built the house he still lives in today in Laketon Township in the early 1960s.

Schubert started many of the sports programs at Laketon Junior High and later Reeths-Puffer High School and coached just about every sport. When he wasn't coaching, he was officiating everything from middle school to college - for almost 60 years in football and basketball, and 64 years in track & field.

Schubert was also a huge advocate for getting more kids involved in officiating, and regularly donated his time to host officiating clinics.

Muskegon Area Sports Hall of Fame Legacy Award

This year's recipient is the great **Doris Sams**.

Doris Sams was the greatest female baseball player in Muskegon history. During the Muskegon Lassies memorable four and one-half seasons in the All-American Girls Baseball League at Marsh Field, Sams was the team's top player and one of the premier players in the league's 11-year run.

Sams was a star at the plate and on the mound, earning league player of the year honors in 1947 and 1949. She led the Lassies to their best-ever season in 1947, notching 11 wins with an 0.98 ERA as the team finished 69-43 and edged out the rival Grand Rapids Chicks in the pennant race. Sams was named to the AAGBL all-star team for six straight seasons from 1947 to 1952. Sams accomplishments included a perfect game and a no hitter.

Sams is the first recipient of the Muskegon Area Sports Hall of Fame's Legacy Award, which was established in 2026 as a way for the hall to honor greats of the past who may have been forgotten, but deserve to be recognized and remembered.

###

Organized in 1986, the Muskegon Area Sports Hall of Fame honors our own heroes and legends, spanning the rich history of sports achievement in the Lake Michigan shoreline area anchored by Ludington to the North and Grand Haven to the south. The Hall of Fame exhibit is located in downtown Muskegon in the Trinity Health Arena and features a fascinating collection of artifacts, photos and commemorative plaques honoring the area's sports heritage.

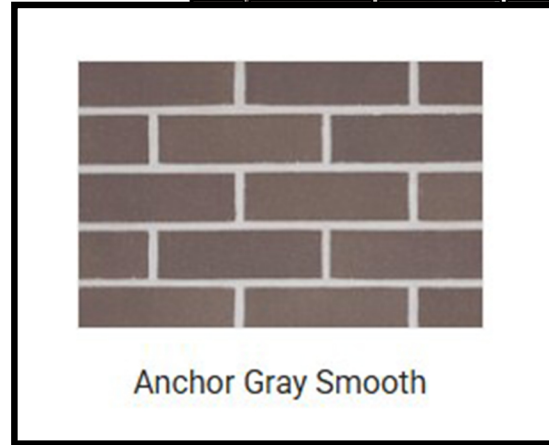
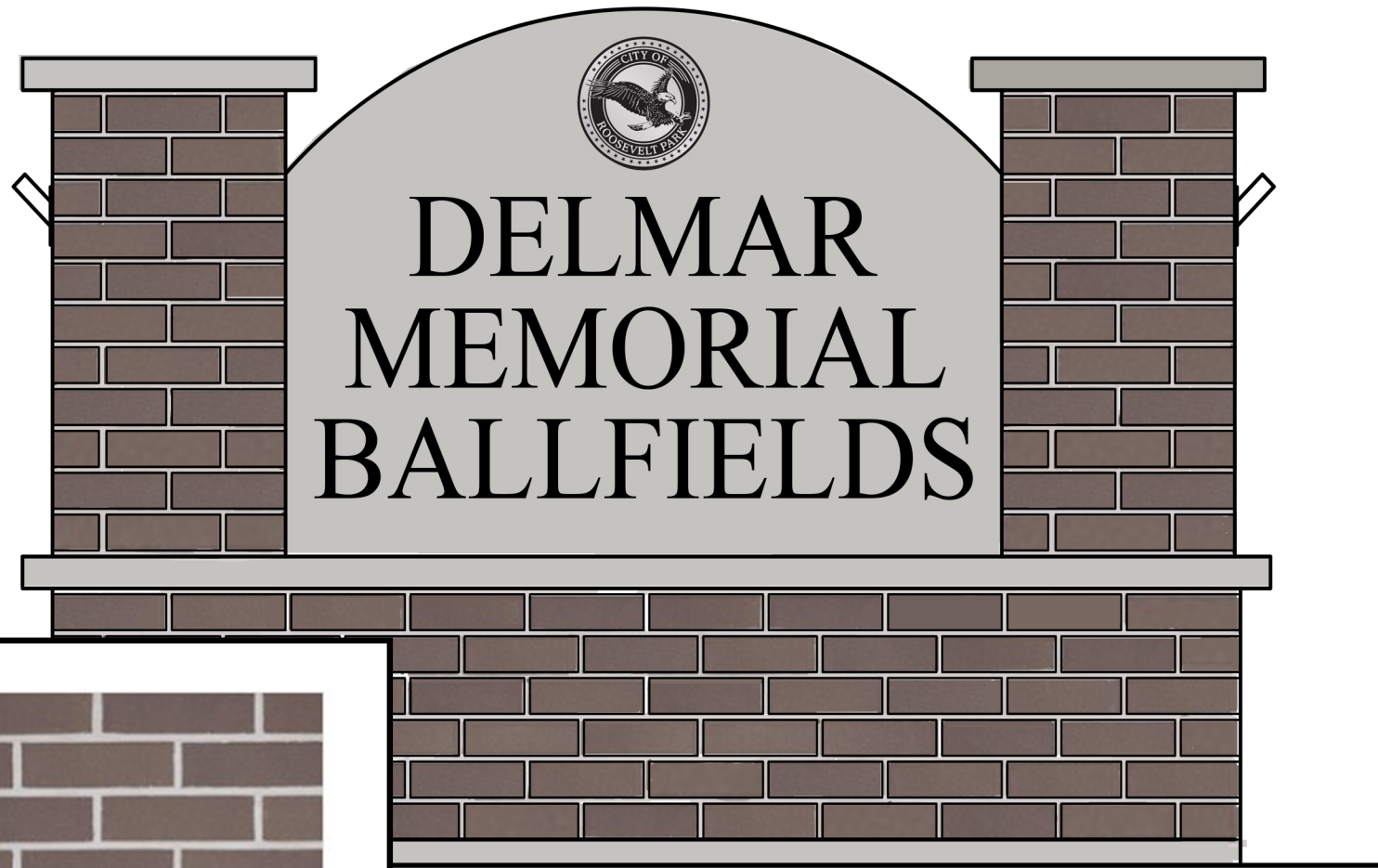

Anchor Gray Smooth

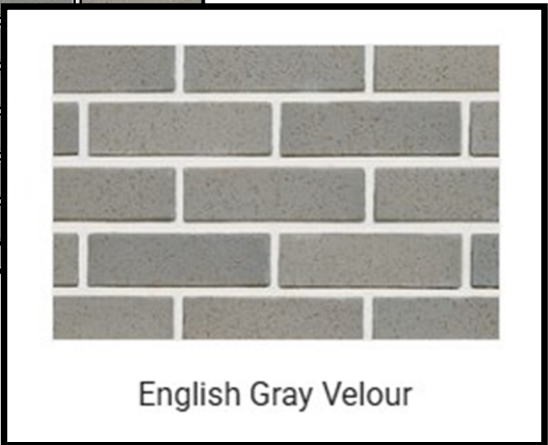
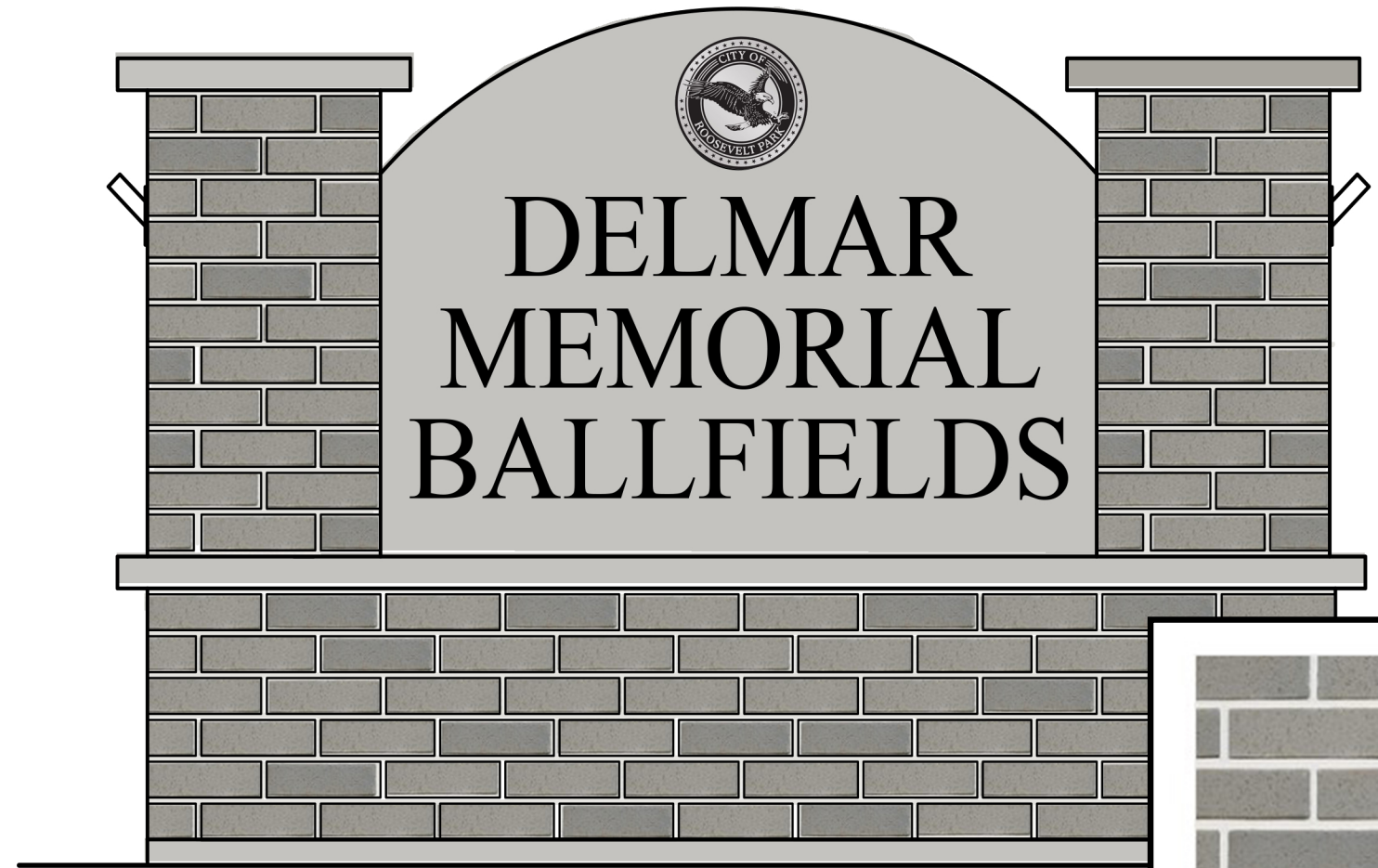

English Gray Velour

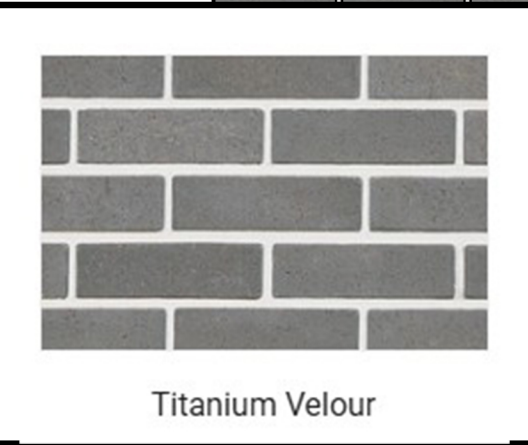
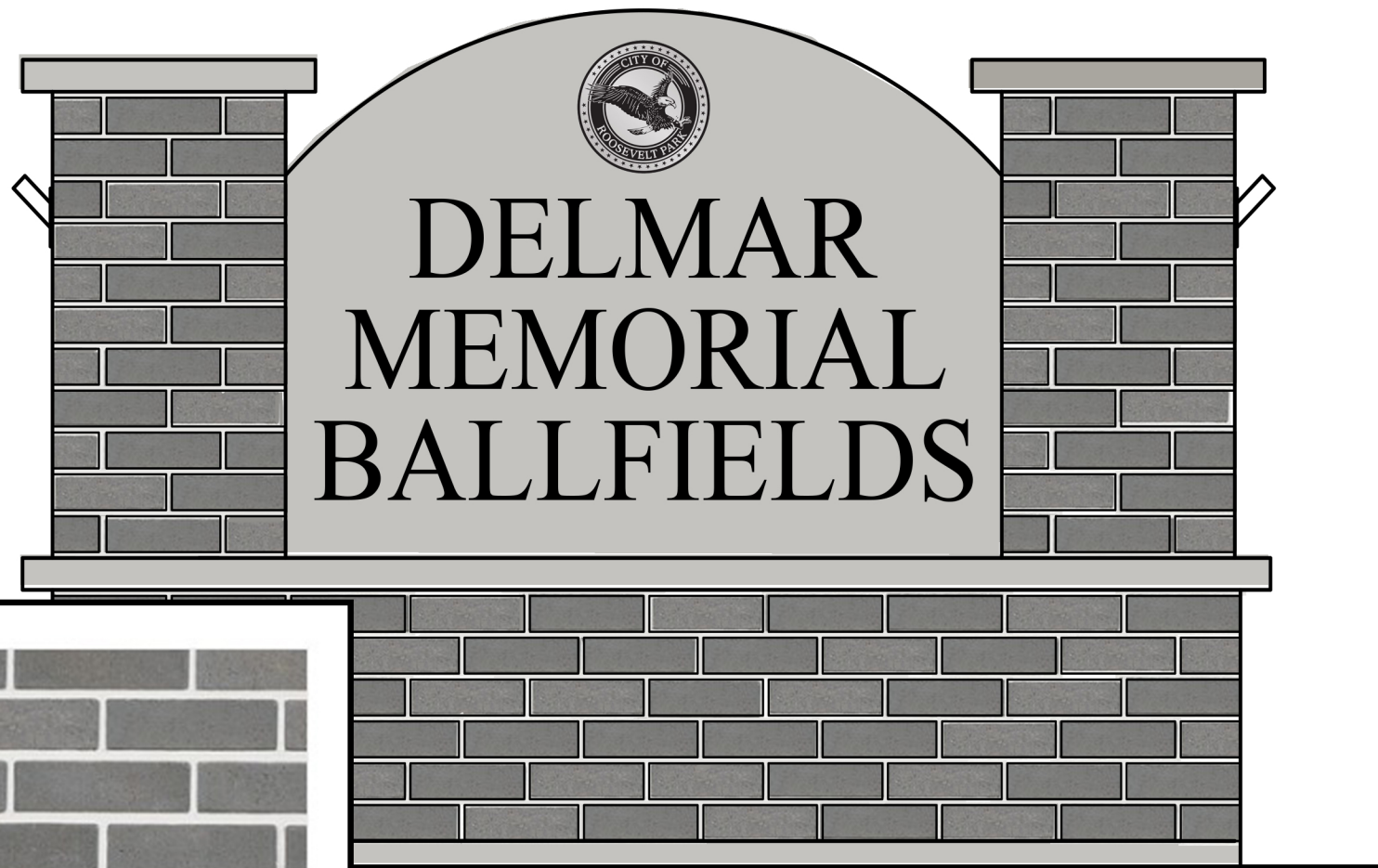

Titanium Velour

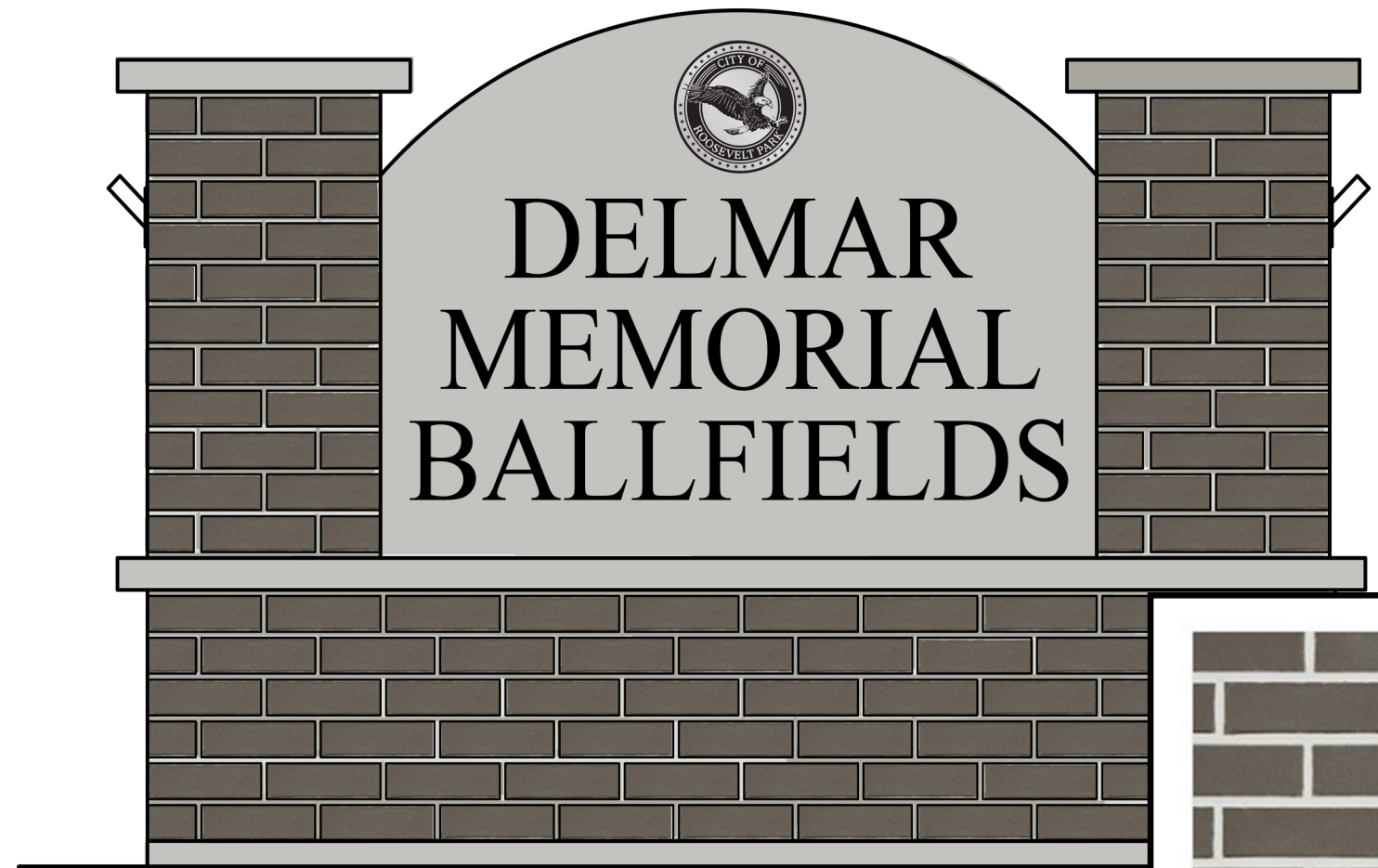

Manhattan Smooth

Delmar Memorial Color Options

GENERAL NOTES:

- PAVEMENT DIMENSIONS AND RADII ARE TO EDGE OF PAVEMENT OR BACK OF CURB.
- DISCREPANCIES BETWEEN SITE AND PLANS SHOULD BE REPORTED TO THE PROJECT MANAGER IMMEDIATELY.
- VERIFY LOCATIONS OF ALL BELOW GRADE UTILITIES PRIOR TO BEGINNING WORK. 72 HOURS BEFORE YOU DIG CALL "MISS DIG" AT 1-800-482-7171.
- VERIFY LOCATIONS OF ALL BELOW GRADE UTILITIES PRIOR TO BEGINNING WORK. 72 HOURS BEFORE YOU DIG CALL "MISS DIG" AT 1-800-482-7171.
- ALL NEW PAVEMENTS AND TURF AREAS ARE INTENDED TO DRAIN FREELY WITH NO PONDING. IF THIS CANNOT BE ACHIEVED USING THE PROPOSED GRADES, NOTIFY THE OWNER'S REPRESENTATIVE IMMEDIATELY FOR RESOLUTION.
- ALL NEW PAVEMENT SHALL MATCH EXISTING ADJACENT PAVEMENT FLUSH, TYPICAL.
- ADJUST TOP OF EXISTING MANHOLES, CATCH BASINS, VAULT COVERS, ETC. TO NEW FINISH GRADE AS REQUIRED.

BARRIER-FREE NOTES

- BARRIER-FREE PARKING AND ACCESSIBLE ROUTE(S) MUST COMPLY WITH THE AMERICANS WITH DISABILITIES ACT AND MICHIGAN BARRIER-FREE CODE REQUIREMENTS, INCLUDING BUT NOT LIMITED TO THE FOLLOWING:
- 1:50 (2%) MAXIMUM CROSS-SLOPE ON ACCESSIBLE ROUTE.
 - NO CHANGES IN LEVEL GREATER THAN 1/2" ALONG ACCESSIBLE ROUTE.
 - 1:20 (5%) MAXIMUM LONGITUDINAL SLOPE ON ACCESSIBLE ROUTE (EXCEPT WHERE RAMPS ARE PROVIDED).
 - 1:50 (2%) MAXIMUM SLOPE (IN ANY DIRECTION) IN B.F. PARKING AND ACCESS AISLES.

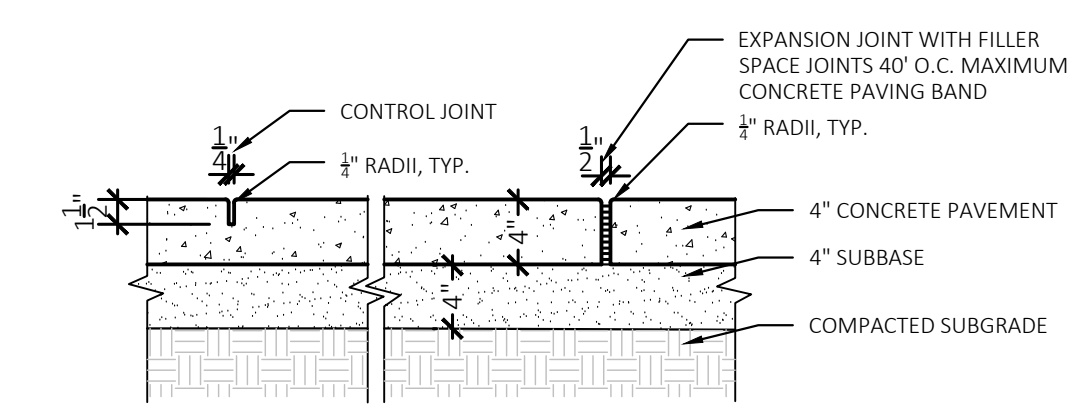
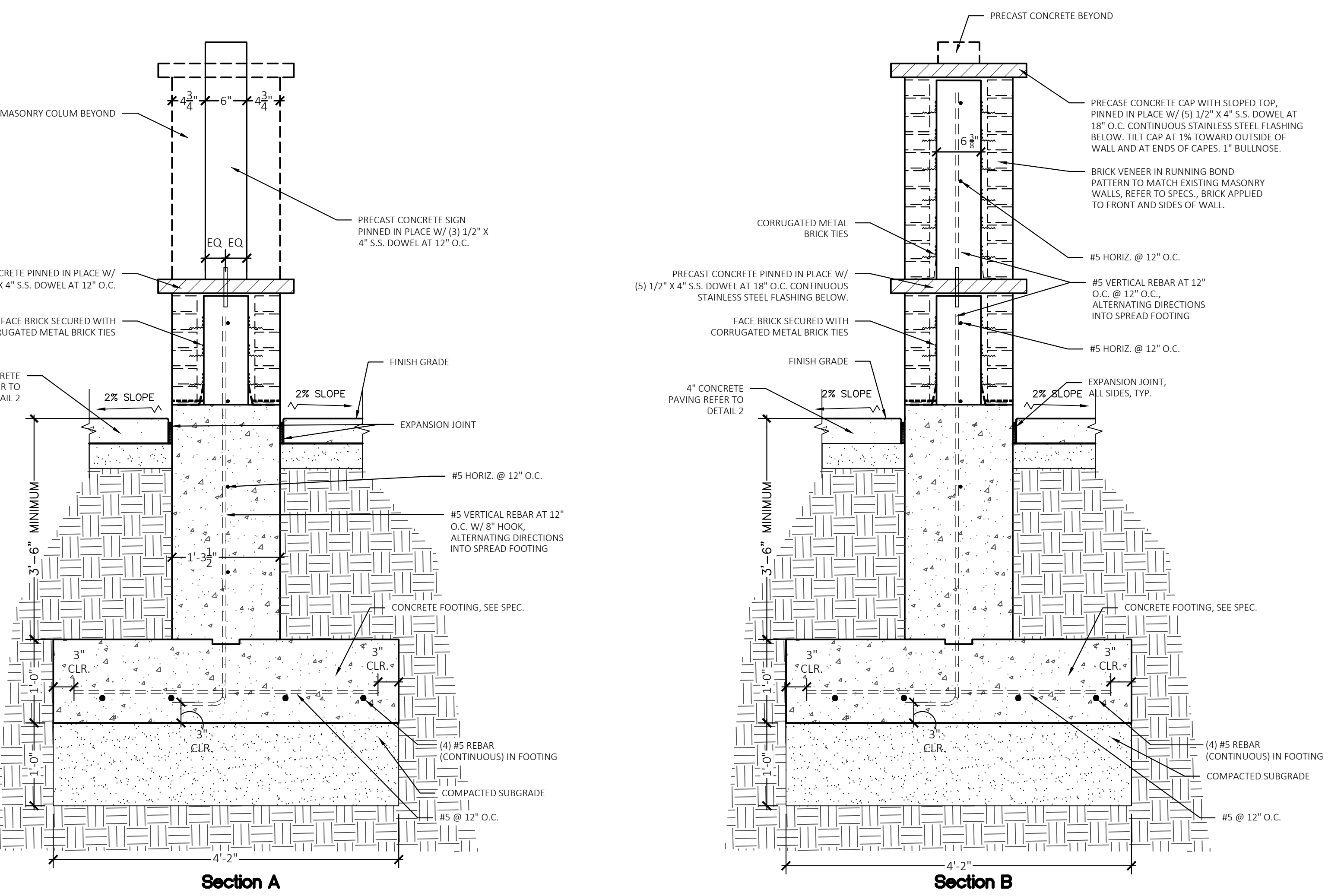
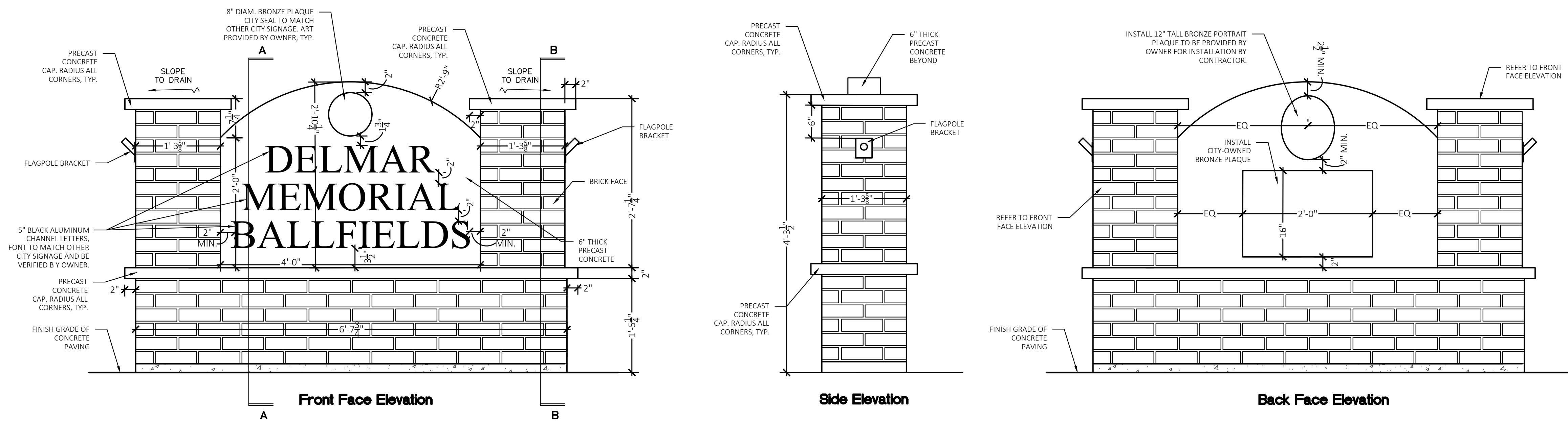

2 4" Concrete Paving
NOT TO SCALE

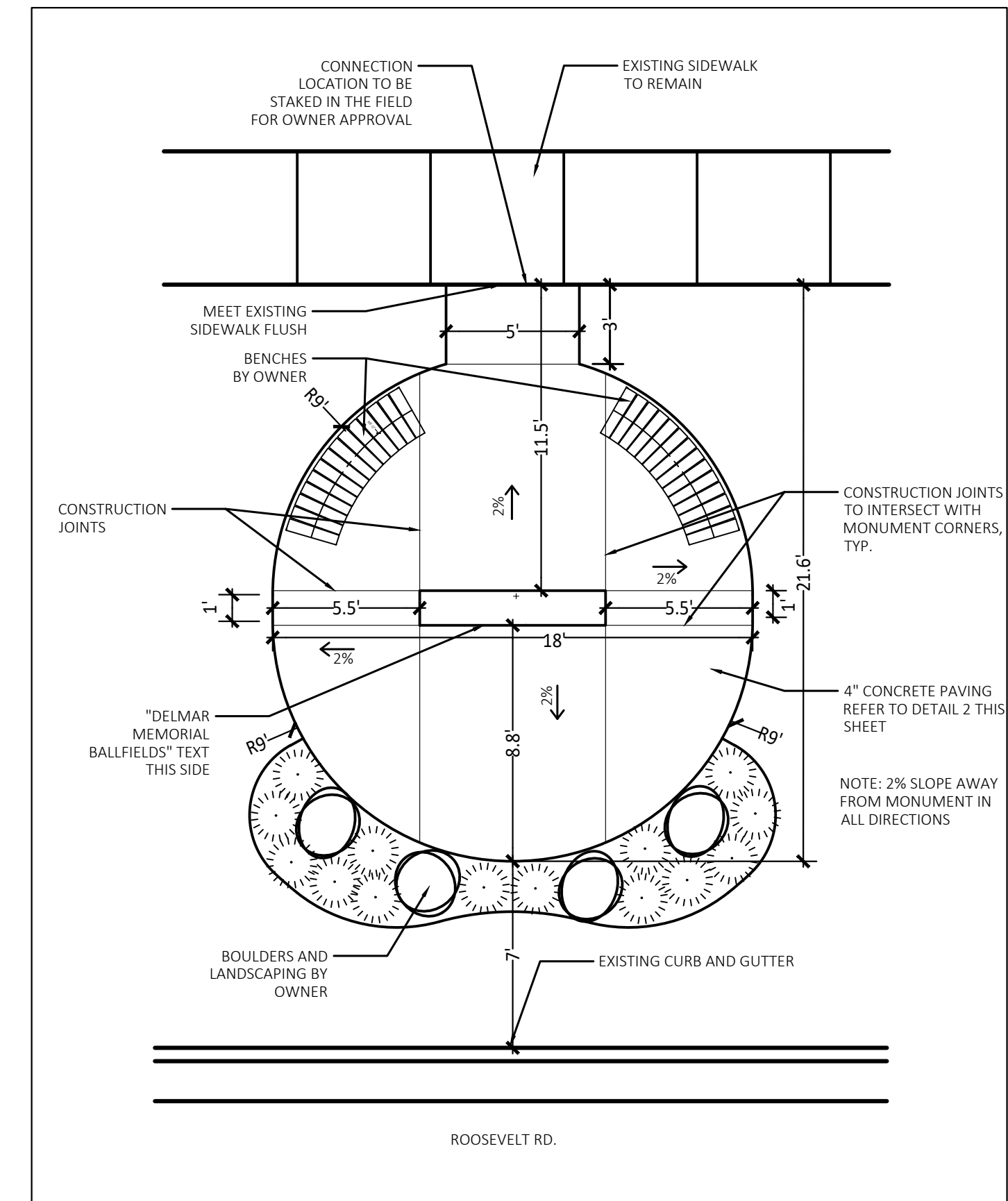

3 Monument Layout
NOT TO SCALE

1 Memorial Sign
NOT TO SCALE

HARD COPY IS INTENDED TO BE 24"X36" WHEN PLOTTED. SCALE(S) INDICATED AND GRAPHIC QUALITY MAY NOT BE ACCURATE FOR ANY OTHER SIZES.

Issued For:	Date
BIDDING	5-14-26

Project:
Delmar Memorial
Roosevelt Park, MI
Sheet Title

Layout Plan + Details